

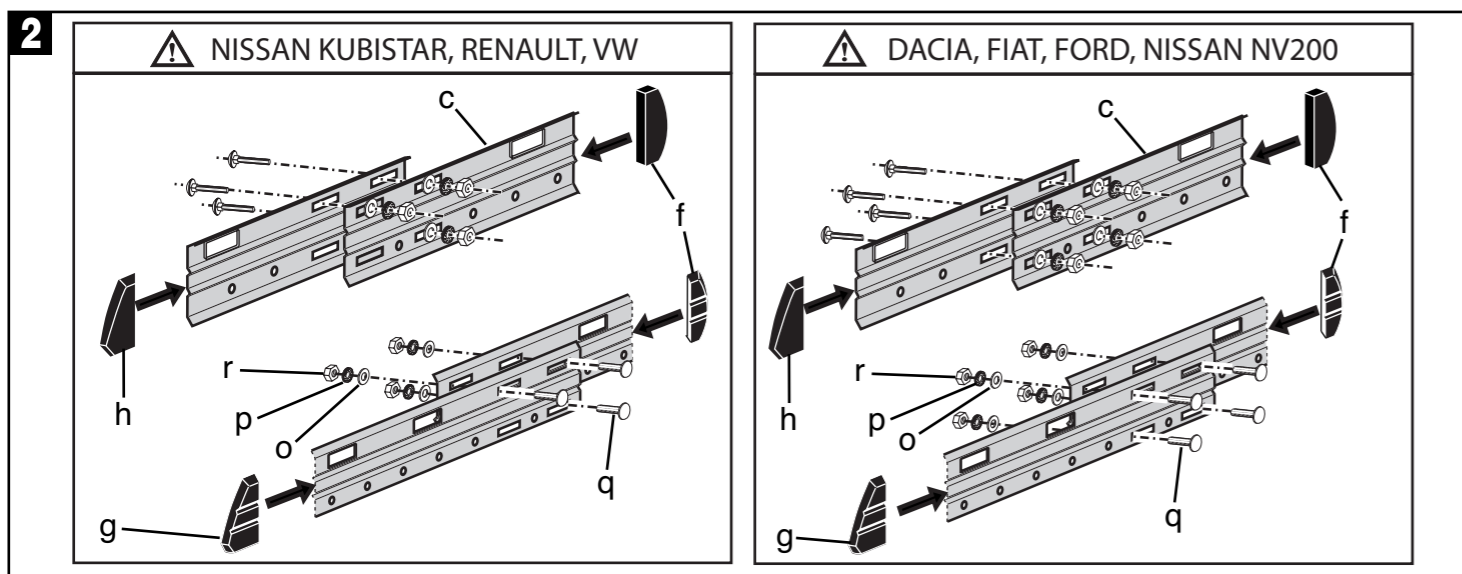

**Assemblage - Assembly - Fijaciones - Verbindungen - Assemblaggio - Montaż -  
Assemblages - Montagens - Összeszerelés - Сборка - Συνδέσεις - Montage -  
Montáž - Ansamblu - Surinkimas - Montāža - Monteerimine - Montáž - Montaža -  
Montaža - Montaža**

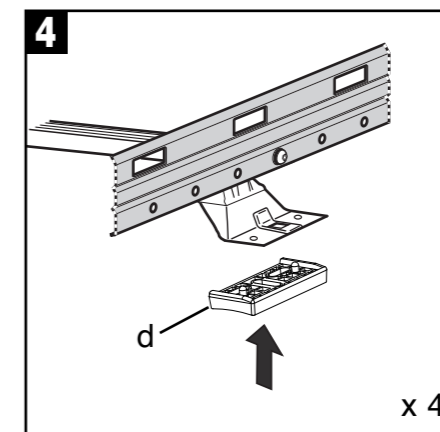

**Montage sur véhicule - Fitting on vehicles - Colocación en vehículos -  
Montagen auf Fahrzeugen - Montaggio su veicoli - Montowanie na pojazdach -  
Montage op voertuigen - Montagens em veículos - Felszerelés gépjárműre -  
Монтаж на автомобил - Τοποθέτηση στο όχημα - Montage på køretøjer -  
Montáž na vozidlo - Montaj pe vehicul - Montavimas ant transporto priemonės -  
Transporta līdzekļa montāža - Sõidukitele paigaldamine - Upevnenie na vozidlá -  
Oprema na vozilih - Ugradnja na vozilima - Ugradnja na vozilima**

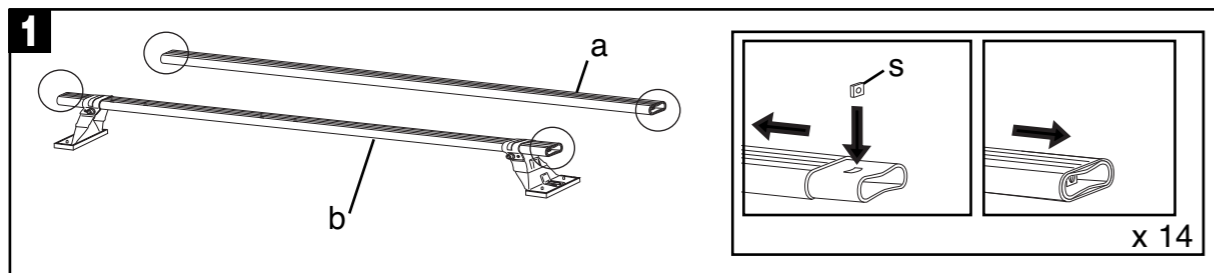