

**RACK MEDIUM
204**

RACK MEDIUM 204

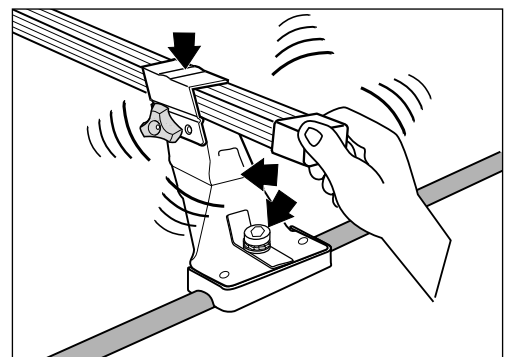

204

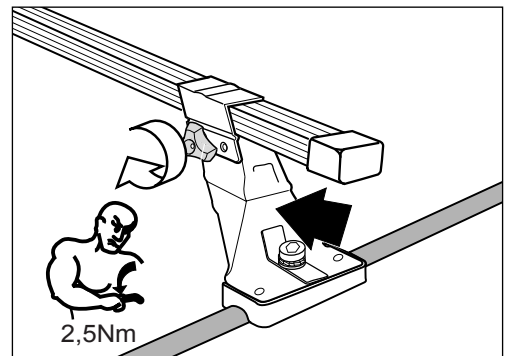
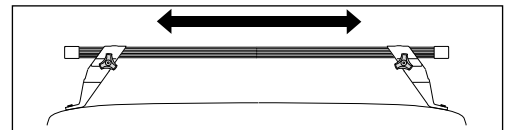
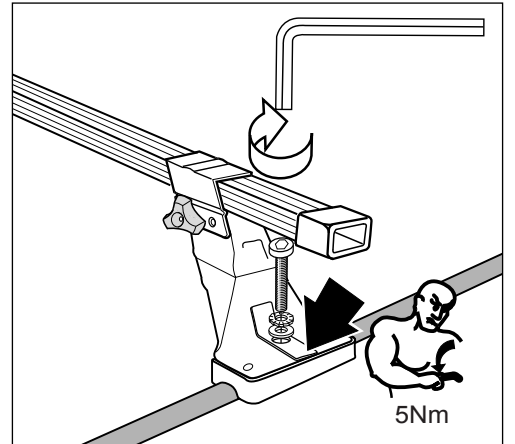
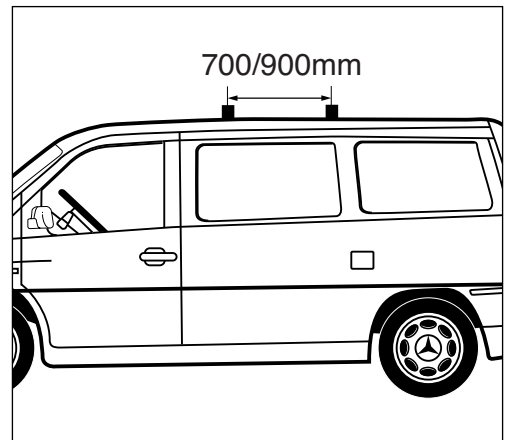
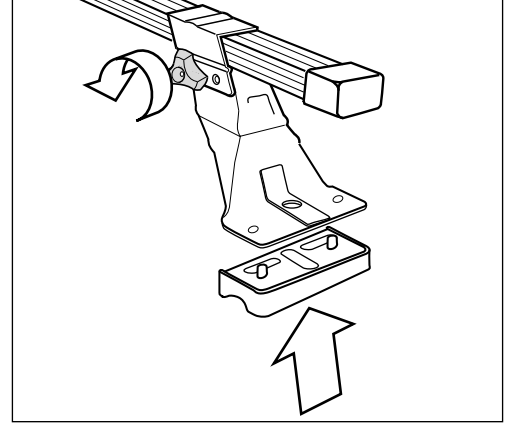
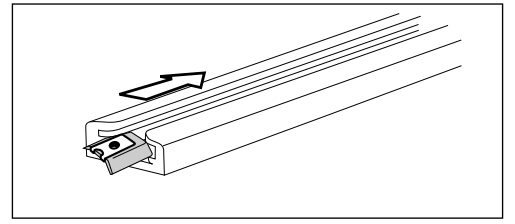

Max. : **75 kg**

Max. : **75 kg**

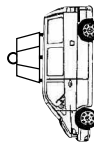

ART : **80104**



**RACK MEDIUM
204**

MERCEDES
VITO⁽²⁾⁽¹¹⁾ 97→03
CLASSE V⁽²⁾⁽¹¹⁾ 97→03

(2) : Pour voiture sans barres ou baguettes latérales d'origine / For cars without original lateral bars or moulding / Für Fahrzeuge ohne serienmäßiger Dachreling oder Ansatzleiste / Para vehiculos sin barras laterales de origen / Per autovettura che d'origine non hanno sbarre laterali / Para carros sem barras nem molduras laterais de origem / Voor auto's zonder door de fabriek gemonteerde standaardbeugels of monterail / na samochody bez relingu

(11) = For vehicles with special fitment in lateral trim - Vehicule avec glissières latérales d'origine - Für Fahrzeuge mit spezieller seitlicher Einrichtung - Veicoli con canaline longitudinali sul tetto - Para vehiculos con correas laterales de origen - Dla samochodów ze specjalnymi miejscami montazowymi w bocznych rylniakach - Voor auto met dakreling - Veículo com pontos de fixação laterais de origem - Gyárilag oldalsó csúszósínnel felszerelt gépjármű - Автомобиль с продольными заводскими направляющими - Όχημα με πλευρικό μηχανισμό ολίσθησης από κατασκευής - For køretøjer med sidelæns trim. - Pro vozidla se zvláštní postranní lištou - Vehicul cu glisieră laterală originală.