

# 912-77x

Lv7 2018-r3

Modelo-model:

## Evo Rack Alu Module A44

Lote-Lot-Lot-Lot:



Peso-Weight-Poids-Gewicht:

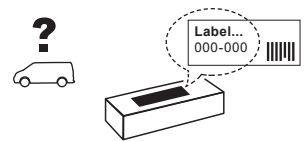

**Max: 180 kg**



CEE - EEC type approval:



26 R- 03 3024



**CITY CRASH** (M)

CRUZBER SA  
ES-A14018311  
P.I. Las Salinas II  
14960 - Rute - Spain  
[www.cruzber.com](http://www.cruzber.com)

- |  |                    |
|--|--------------------|
| <b>(E)</b> Instrucción de montaje<br>¡Leer primero!            | Portaequipajes     |
| <b>(GB)</b> Assembly instructions<br>Read first!               | Roof racks         |
| <b>(F)</b> Instruction de montage<br>Lire en premier!          | Galleries          |
| <b>(D)</b> Montageanleitung<br>Zuerst lesen!                   | Dachgepäckträger   |
| <b>(PT)</b> Instruções de montagem<br>Ler primeiro!            | Porta bagagens     |
| <b>(PL)</b> Instrukcja montażu<br>Najpierw przeczytaj!         | Bagażnik dachowy   |
| <b>(CZ)</b> Montážní návod<br>Čtěte pozorně!                   | Strešní nosiče     |
| <b>(HU)</b> Szerelési Utasítás<br>Először olvasd el!           | Csomagtartó        |
| <b>(RO)</b> Instrucțiuni de montaj<br>Întai cititi!            | Krovni nosač       |
| <b>(HR)</b> Detaljne upute<br>Prvo pročitati!                  | Portbagaj          |
| <b>(GR)</b> Διαβάστε προσεκτικά τις<br>Οδηγίες Συναρμολόγησης! | Μπάρες Οροφής      |
| <b>(TR)</b> Öncelikle montaj:<br>Talimatlarını okuyunuz!       | Taşıyıcı sistem    |
| <b>(RU)</b> Инструкции по монтажу<br>Сначала прочитайте!       | Багажники на крышу |
| <b>(I)</b> Istruzioni di montaggio<br>Leggere per primo!       | Portabagagli       |
| <b>(NL)</b> Montagehandleiding<br>Eerst lezen!                 | Imperiaal          |
| <b>(SLO)</b> Navodila za sestavljanje<br>Preberite!            | Strešne košare     |



1.



- |  |   |
|--|---|
| <b>(E)</b> Contenido embalaje: ¡Verificar! | <b>(RO)</b> Pachetul contine: Verificati!           |
| <b>(GB)</b> Package content: Check!        | <b>(HR)</b> Sadržaj paketa: Provjeri!               |
| <b>(F)</b> Contenu d'emballage: Vérifier!  | <b>(GR)</b> Ελέγξτε το περιεχόμενο: του πακέτου!    |
| <b>(D)</b> Packungsinhalt: Überprüfen!     | <b>(TR)</b> Paket içeriğini: Control ediniz!        |
| <b>(PT)</b> Contéudo embalagem: Verificar! | <b>(RU)</b> Содержание упаковки: Проверьте!         |
| <b>(PL)</b> Zawartość opakowania: sprawdź! | <b>(I)</b> Contenuto della confezione: Controllare! |
| <b>(CZ)</b> Obsah balení: Zkontrolujte!    | <b>(NL)</b> Pakket inhoud: Controleer!              |
| <b>(HU)</b> Csomag tartalma: Ellenőrizd!   | <b>(SLO)</b> Vsebina paketa: Preverite!             |

|                   | 912-777                                      | 912-778                                      |
|-------------------|--|--|
|                   | 1x (861-128)<br>1x (861-144)                 | 1x (861-128)<br>1x (861-144)                 |
|                   | 1x (821-146)<br>158 cm                       | 1x (821-148)<br>170 cm                       |
|                   | 12x (827-466)<br>158 cm                      | 12x (827-468)<br>170 cm                      |
|                   | 1x (716-374)<br>158 cm                       | 1x (716-375)<br>170 cm                       |
|                   | 1x (805-169)<br>1x (805-186)<br>2x (855-223) | 1x (805-169)<br>1x (805-186)<br>2x (855-223) |
| Lote / Lot        | 02-21  | 02-21  |
| <br>Peso / Weight | 38,00 kg                                     | 38,50 kg                                     |

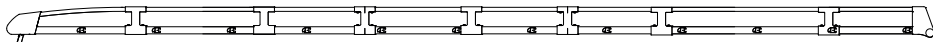

2.

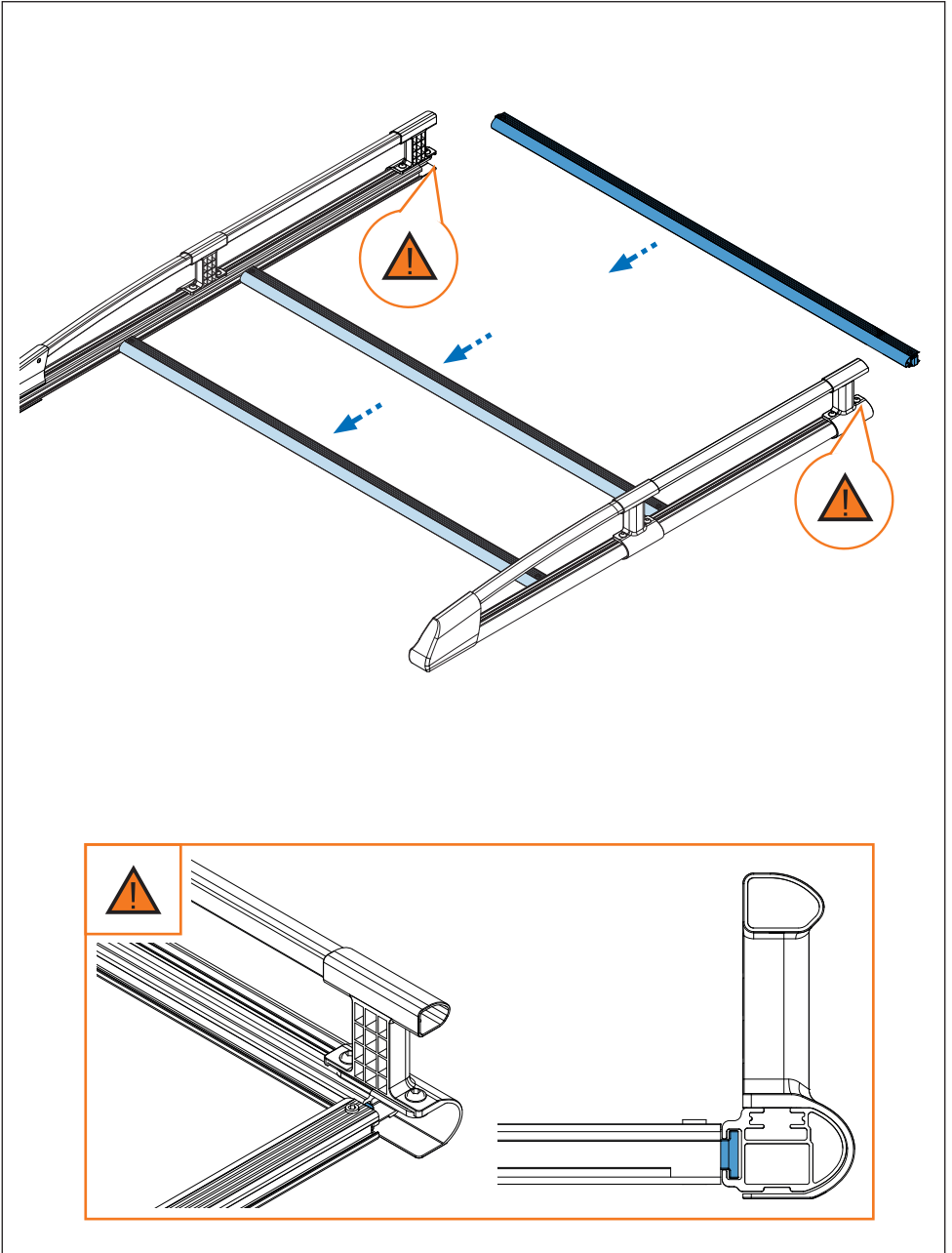

3. 

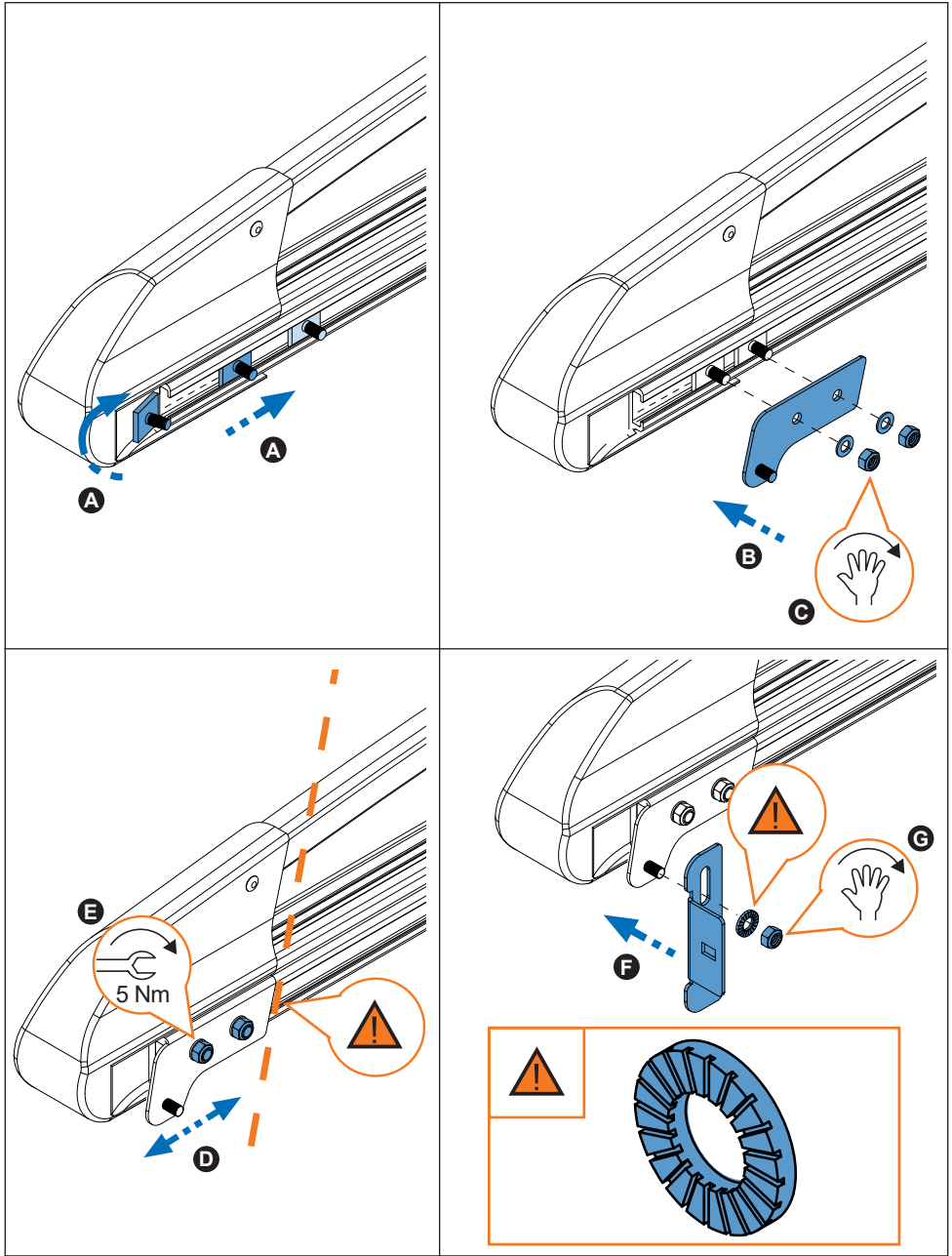

4. 

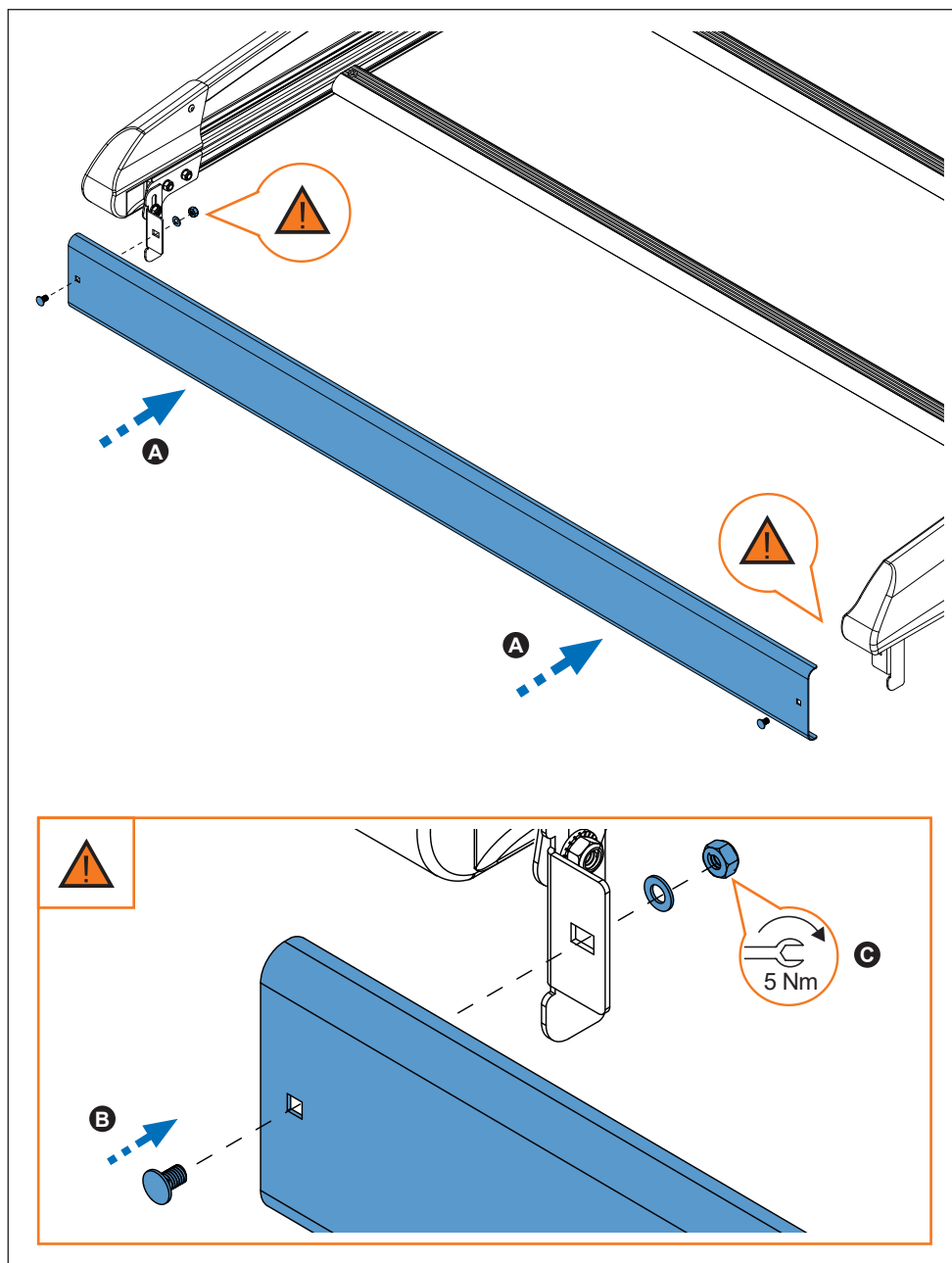

5. 

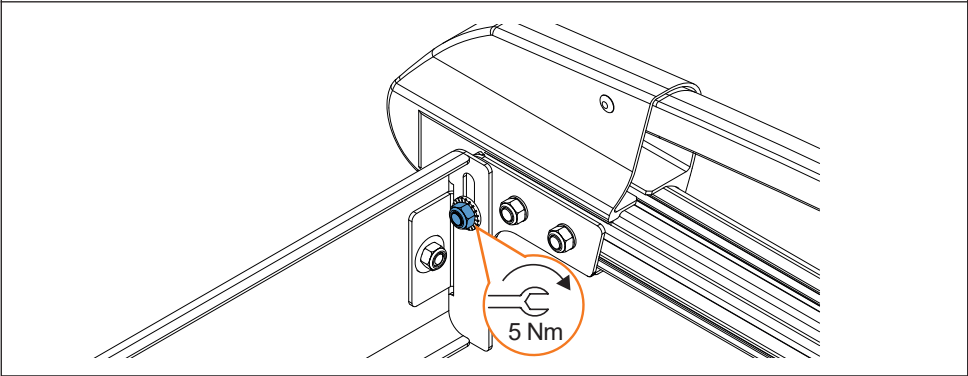
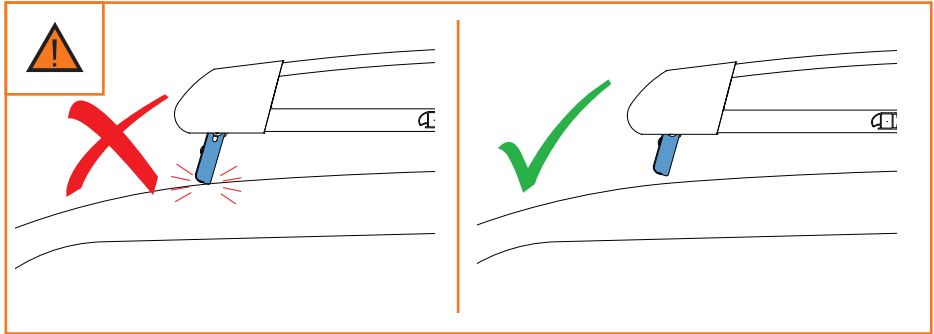
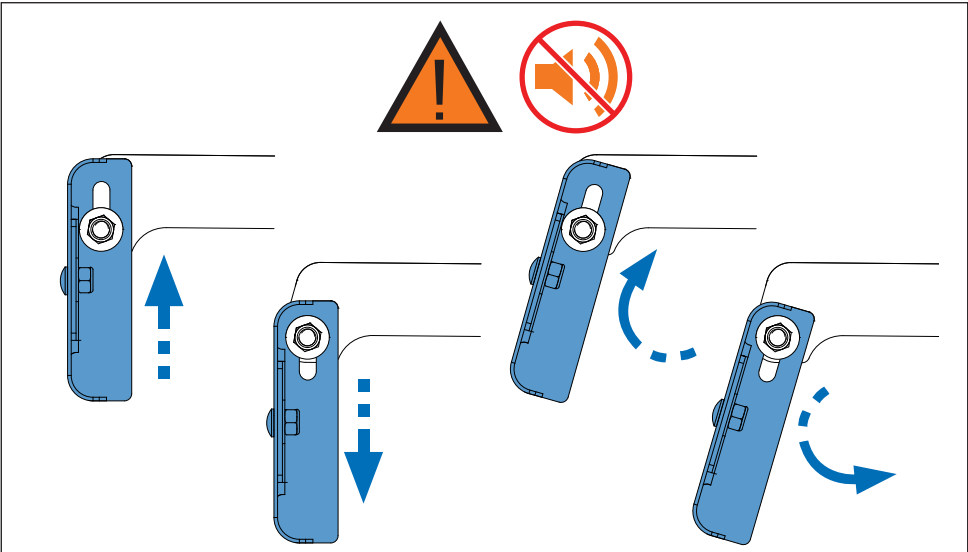

6. 

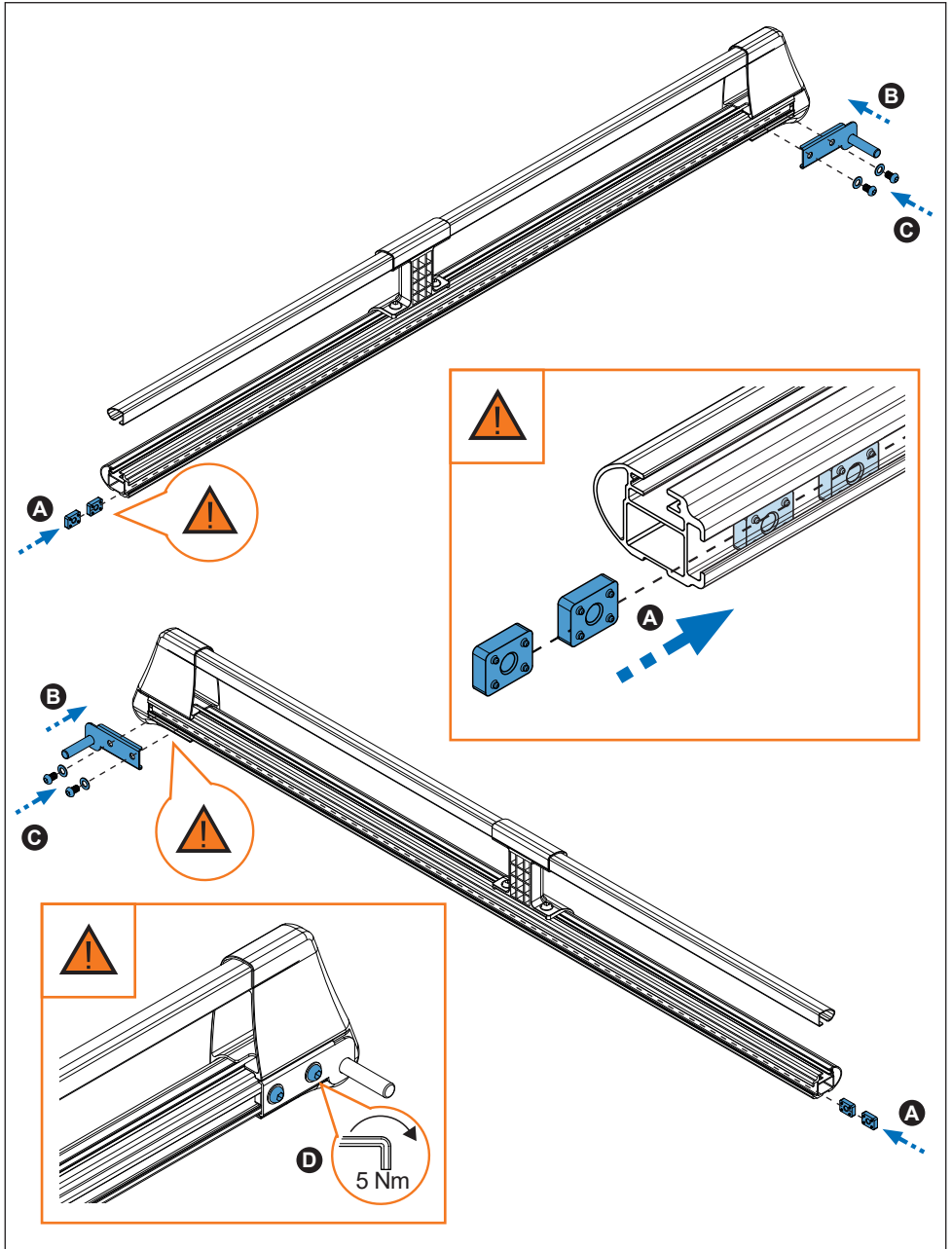

7. 

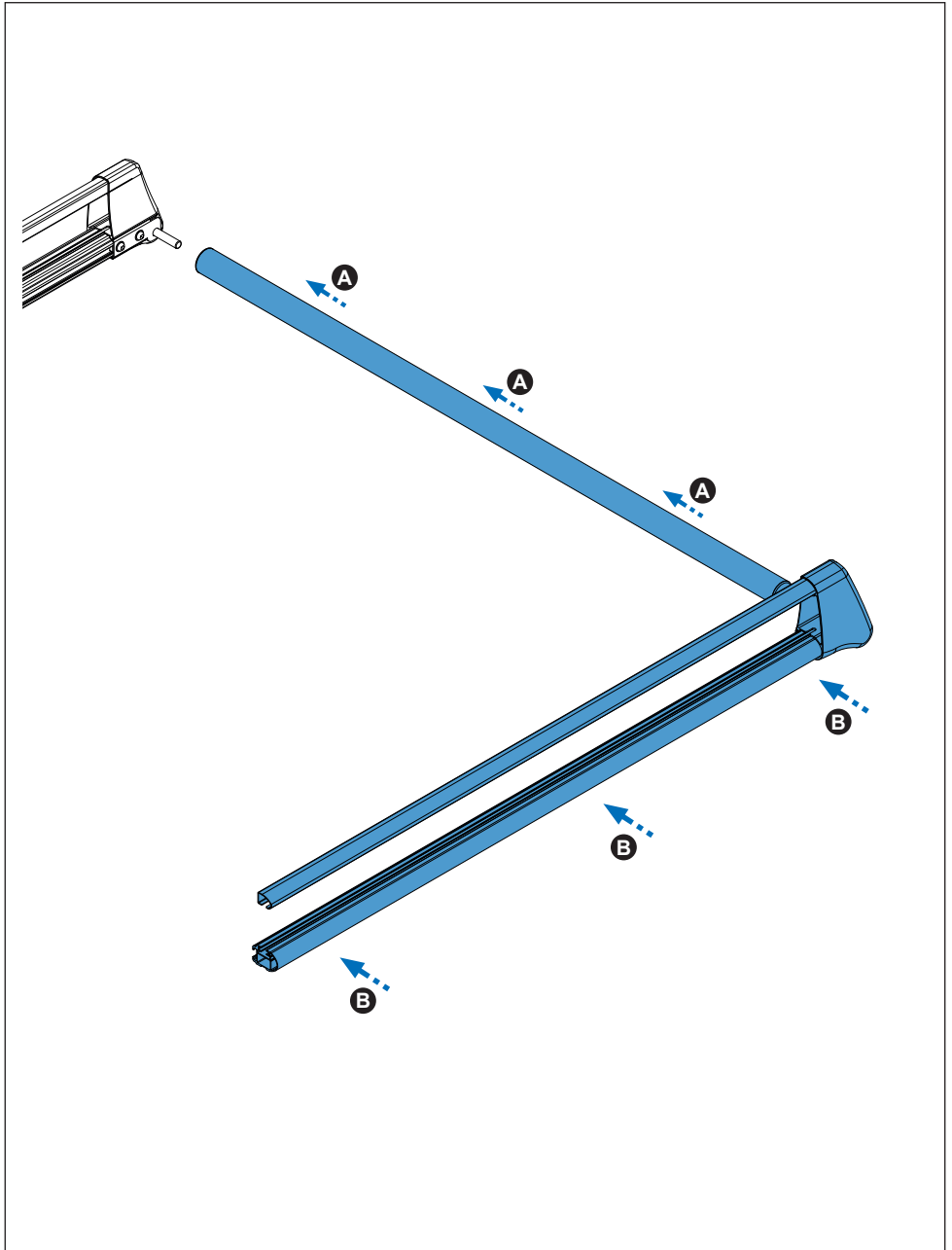



8. 

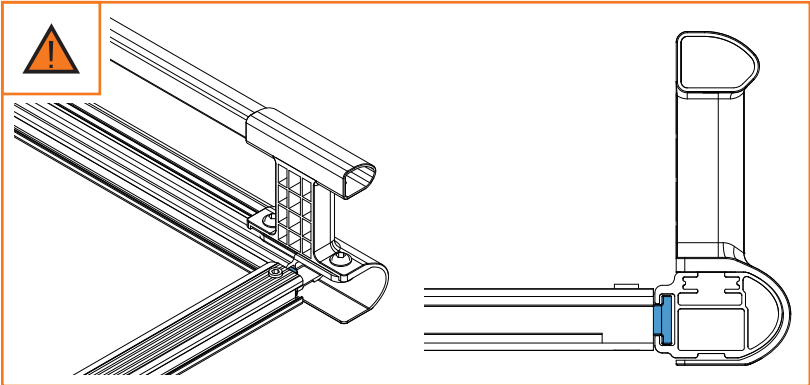
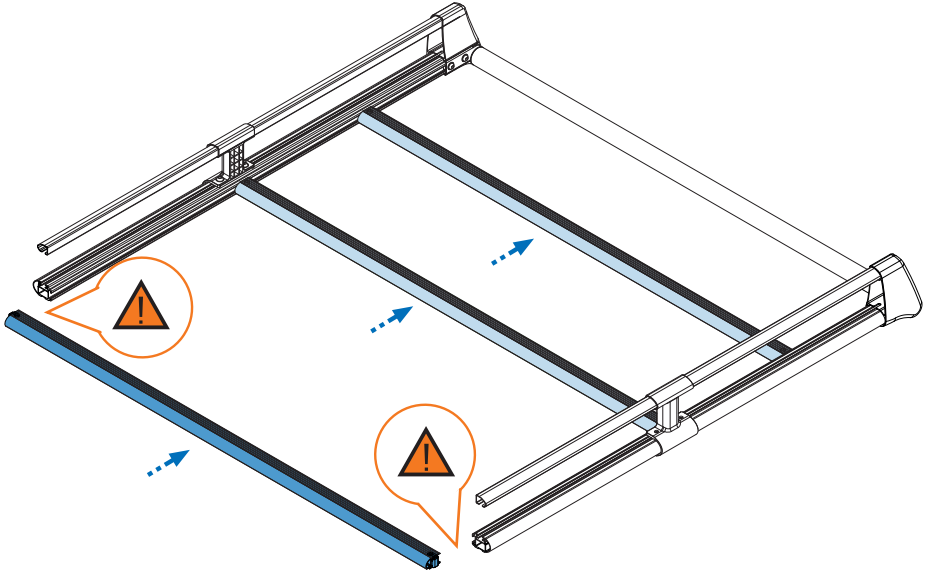

9. 

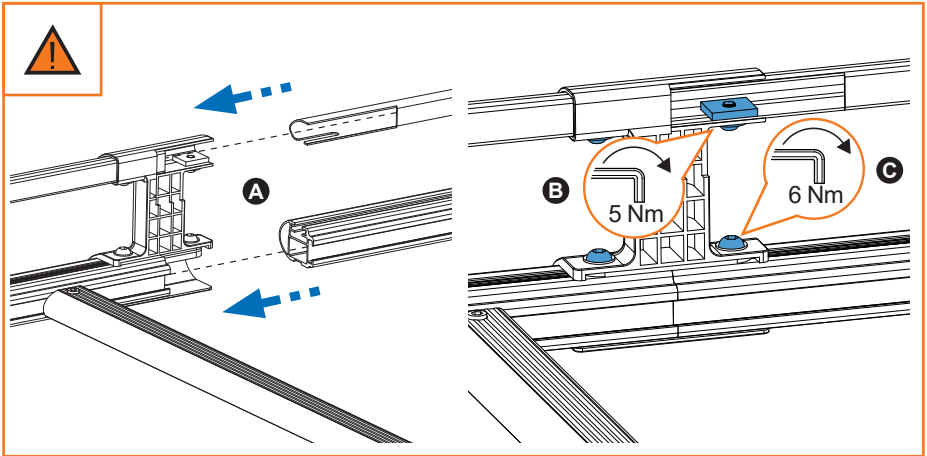
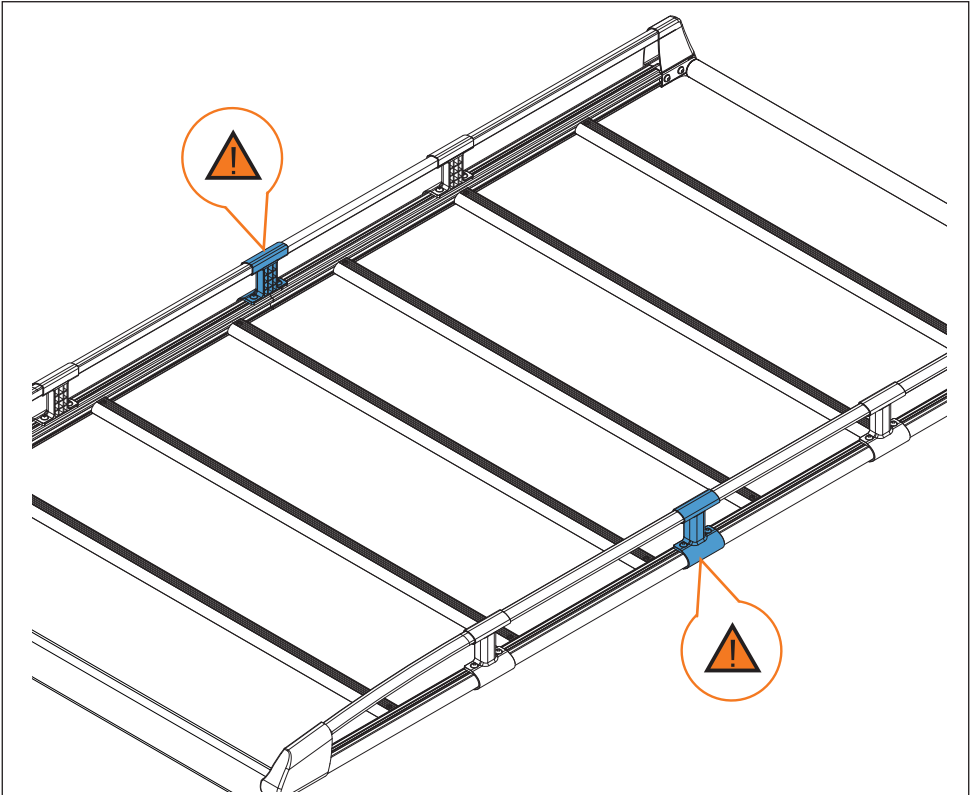

10.

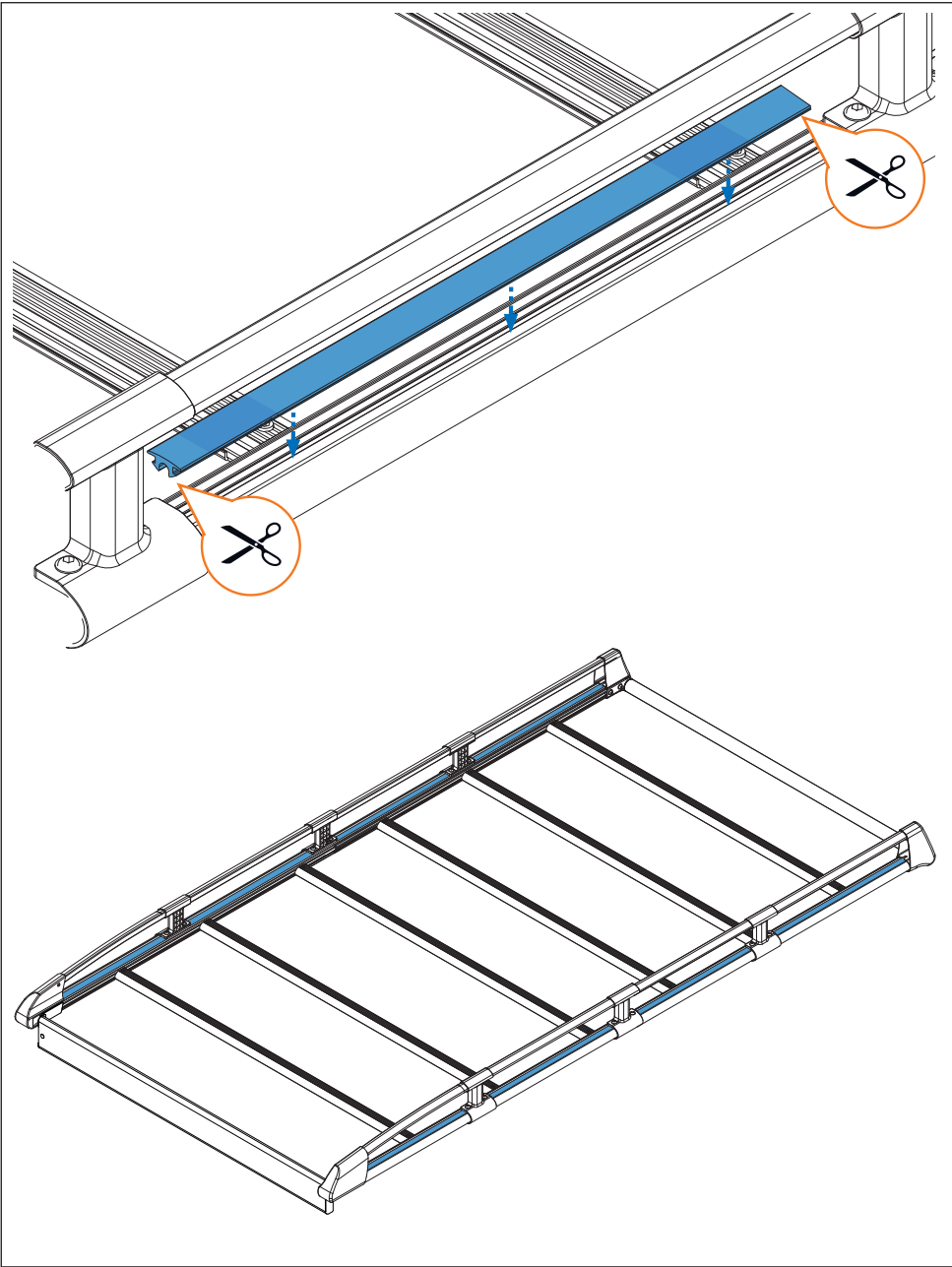

11.

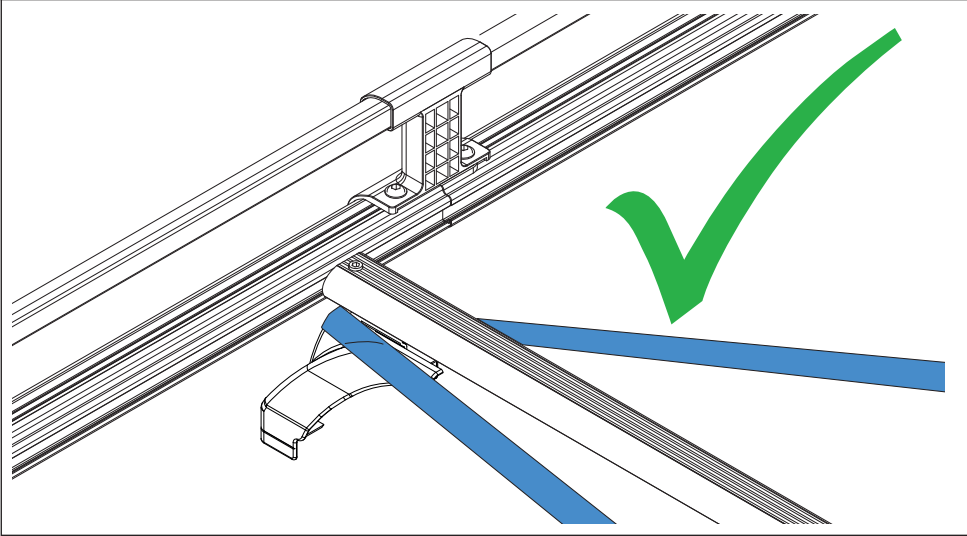
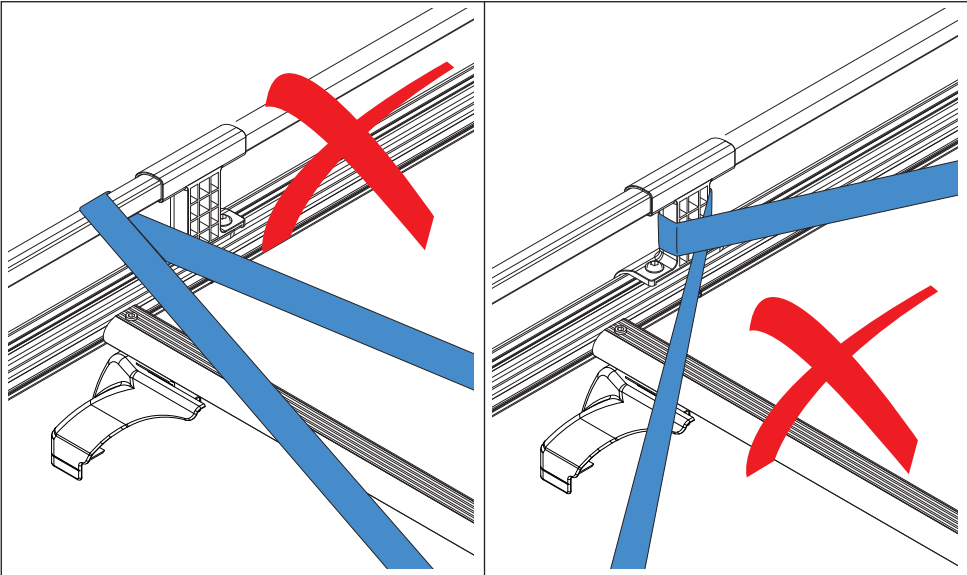

3

