

ISSUE:	DRAWN BY:	CHECKED BY:	CRF No:	DATE:	DESCRIPTION:
a	SJ	KB	2758	02/08/22	First Issue
b					
c					
d					
e					
f					
g					
h					
i					
j					
k					
l					
m					

VC4PR/FL KammBar Instructions

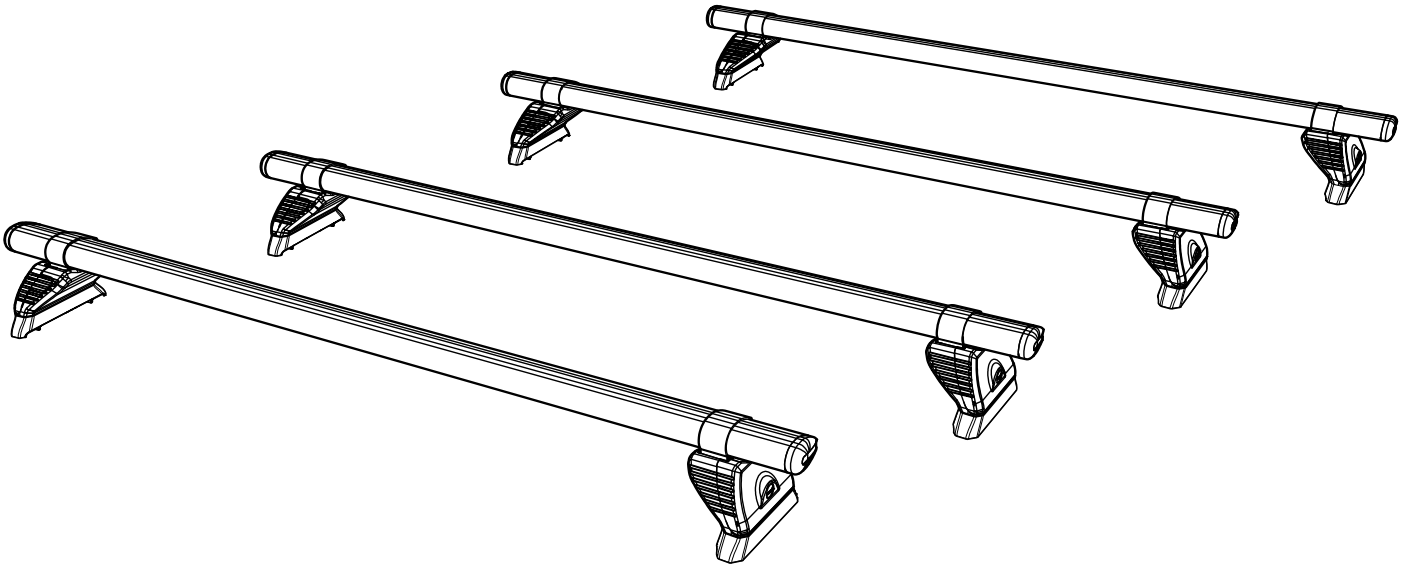

CITY CRASH (✓)

According to ISO/ PAS 11154:2006

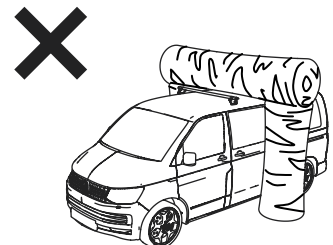
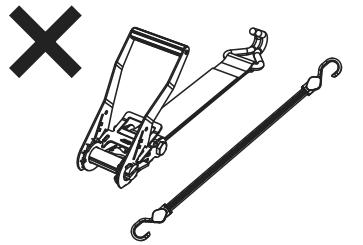
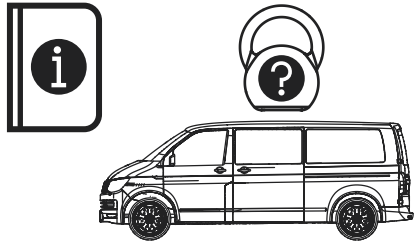
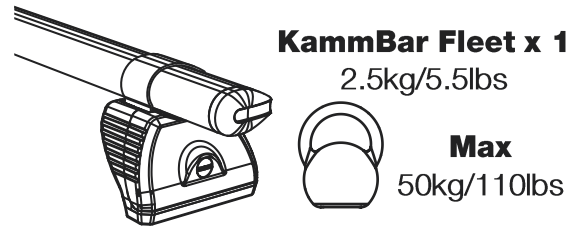

KammBar Pro

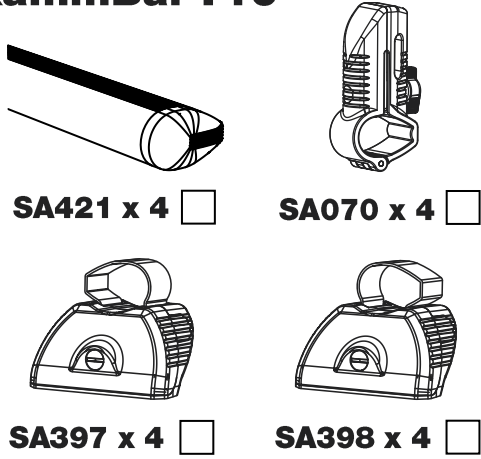

KammBar Fleet

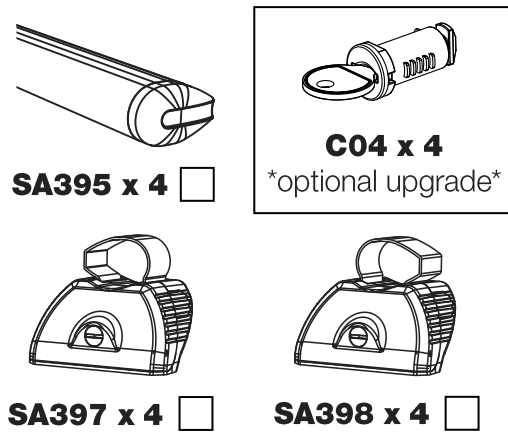

Fitting Kit

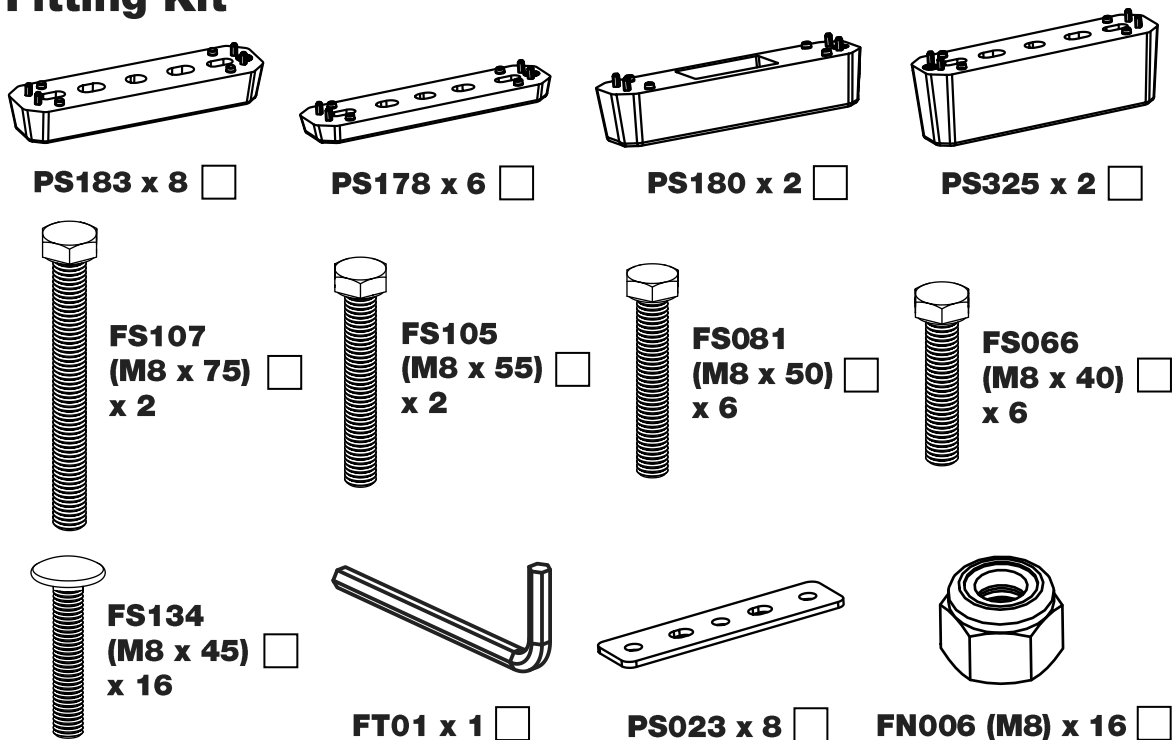

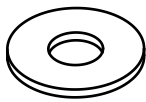

FW002 (M8) x 16

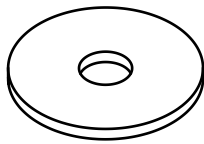

PS208 (M8) x 8

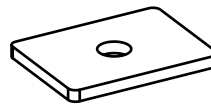

PS020 (M8) x 8

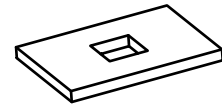

MS209 (M8) x 16



L3 = B

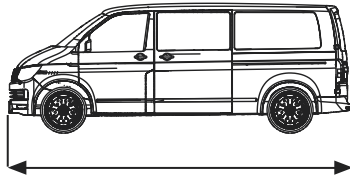

5986mm

L3 (T-Track) = C

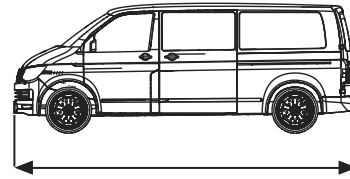

5986mm

L4 = A

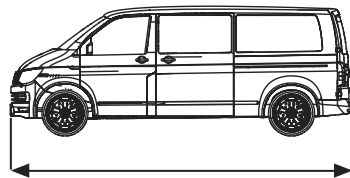

6850mm

L4 (T-Track) = C

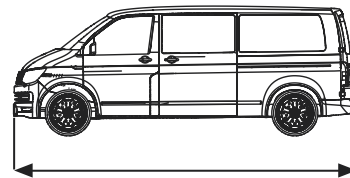

6850mm

L5 = A

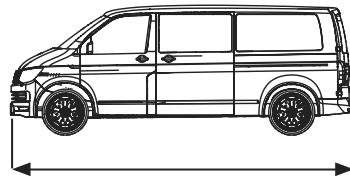

7391mm

L5 (T-Track) = C

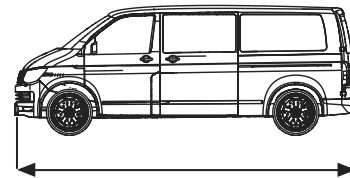

7391mm

1.

A/B

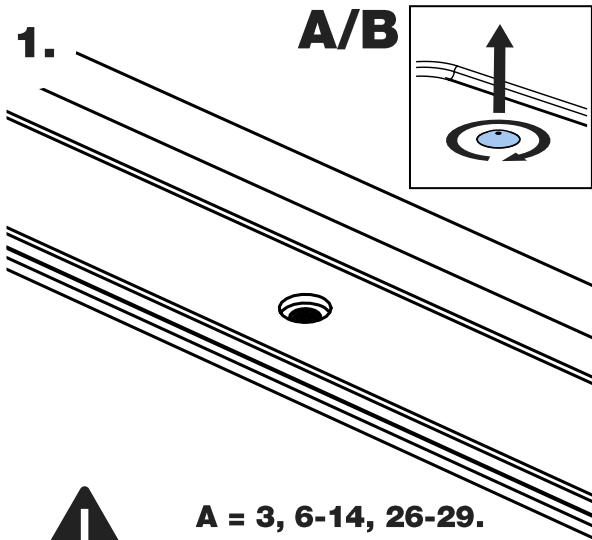
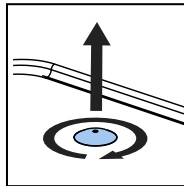

**A = 3, 6-14, 26-29.
B = 4, 6-7, 15-21, 26-29.**

2.

C (T-Track)

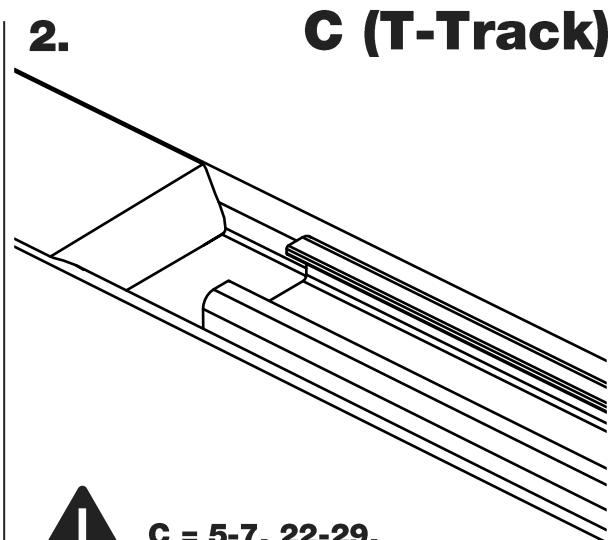

C = 5-7, 22-29.

3.

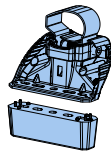

SA397

PS325

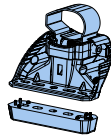

SA397

PS183

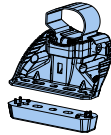

SA397

PS183

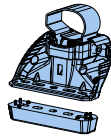

SA397

PS183

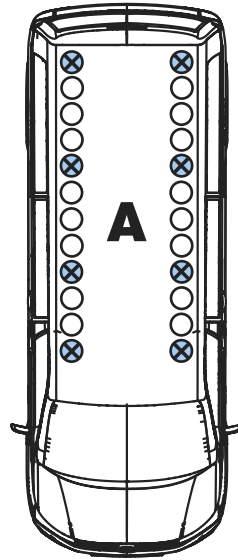

SA398

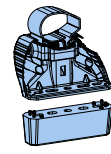

PS325

SA398

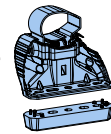

PS183

SA398

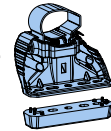

PS183

SA398

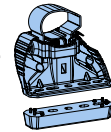

PS183

4.

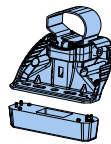

SA397

PS180

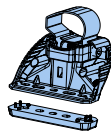

SA397

PS178

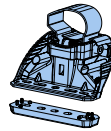

SA397

PS178

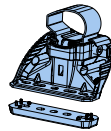

SA397

PS178

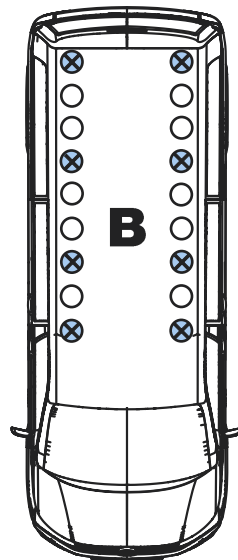

SA398



PS180

SA398

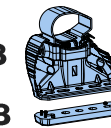

PS178

SA398

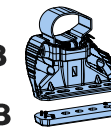

PS178

SA398

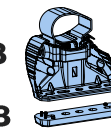

PS178

5.

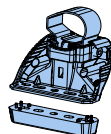

SA397

PS183

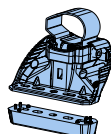

SA397

PS183

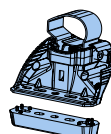

SA397

PS183

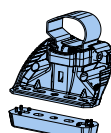

SA397

PS183

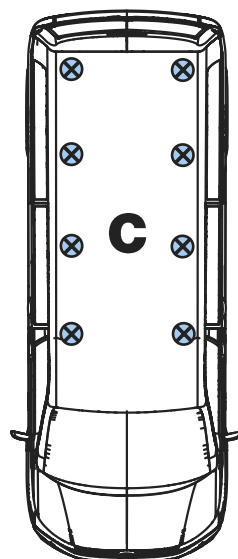

SA398

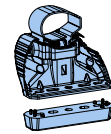

PS183

SA398

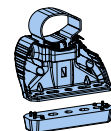

PS183

SA398

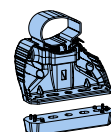

PS183

SA398

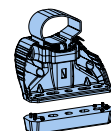

PS183

6.

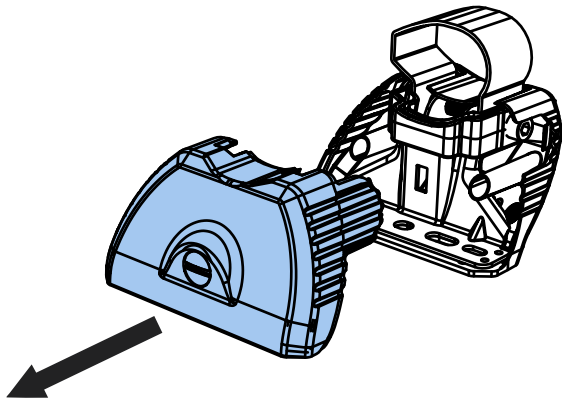

7.

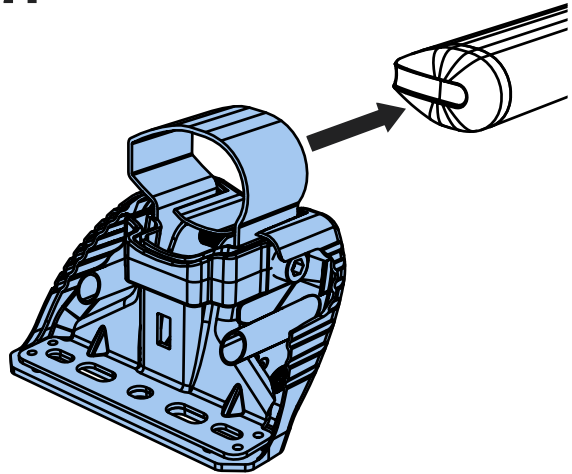

8.

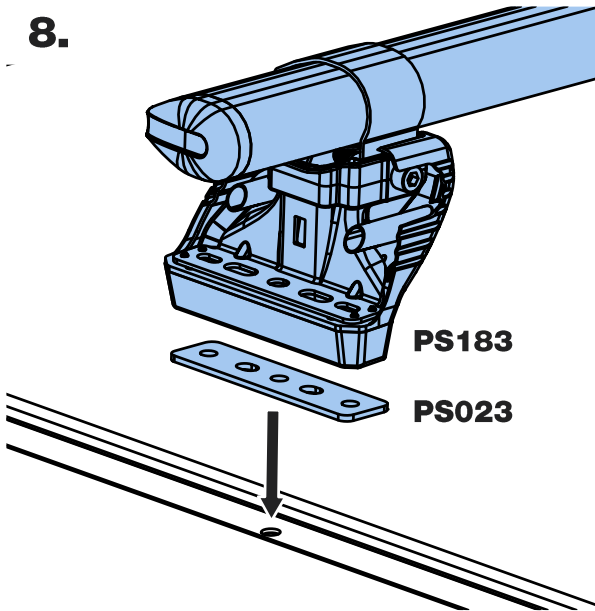

9.

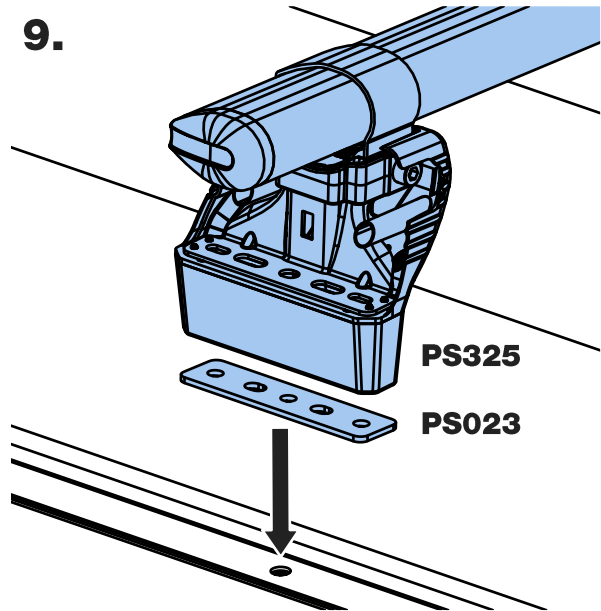

10.

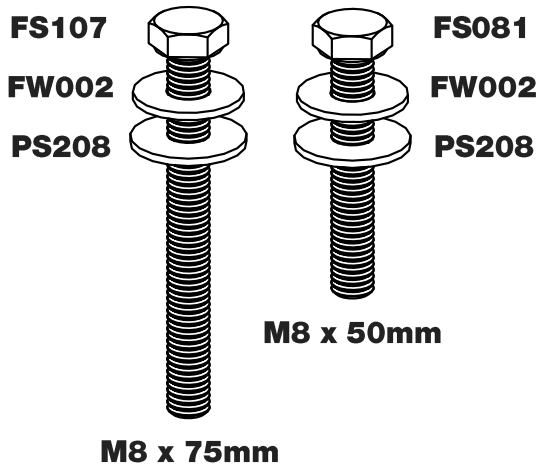

11.

