

TB3HKR

KammRack

Instructions

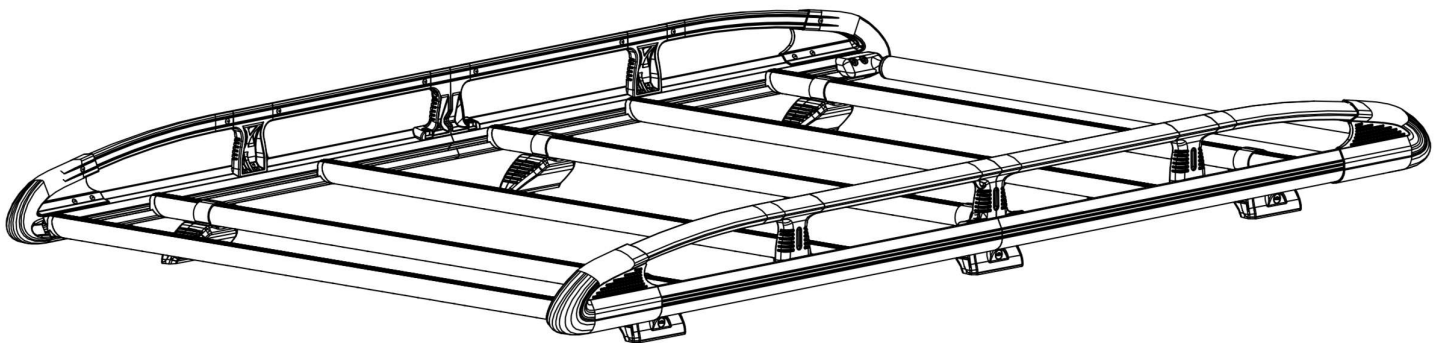

CITY CRASH (✓)

According to ISO/ PAS 11154:2006

TB3HKR:

Ford Transit Custom, 2014–

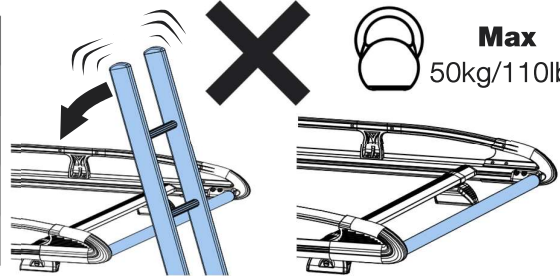
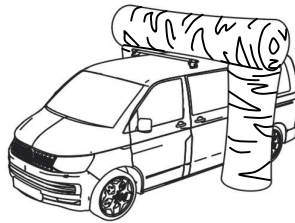
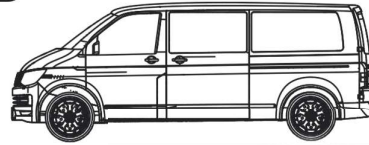

KammRack

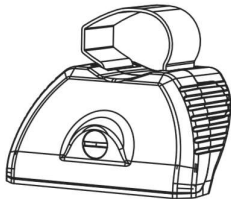

SA397U x 3

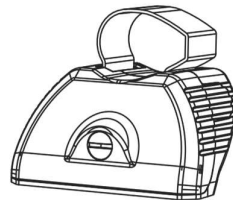

SA398U x 3

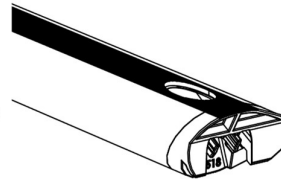

SA428



C04 x 6
optional upgrade

LHS x 2

RHS x 2

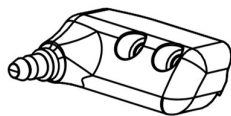

PS519 x 1

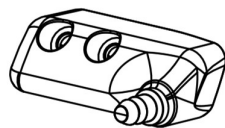

PS520 x 1

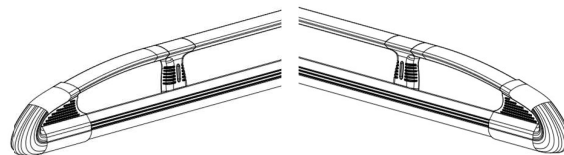

ASF x 1

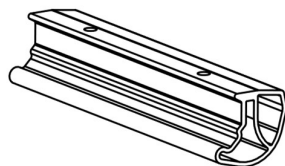

EXT15-02 x 2

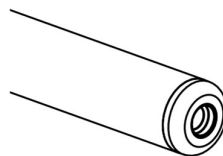

SA436 x 1

Fitting Kit

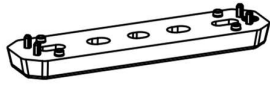

PS178 x 4

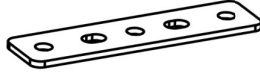

PS023 x 6

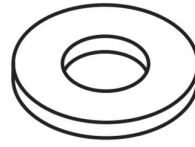

FW002 (M8) x 6

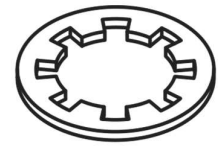

FW009 (M8) x 6



**FS101
(M8 x 45) x 6**

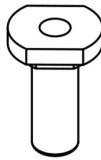

FN035 (M8) x 6



FT01 x 1

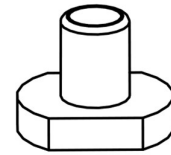

FN085 x 16



**FS059
(M8 x 25) x 16**



FT05 x 1



1.

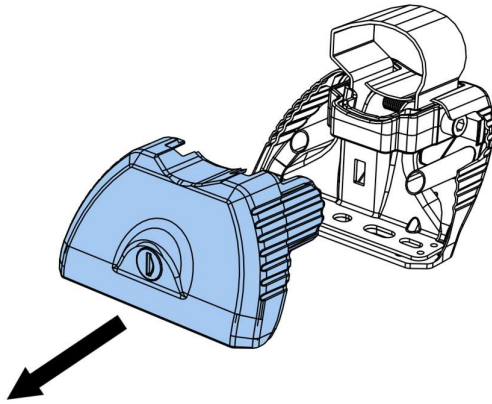

2.

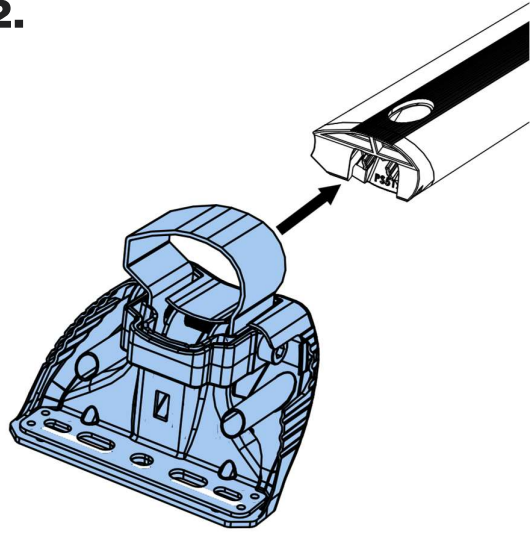

3

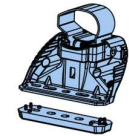

SA397U
PS178



SA397U

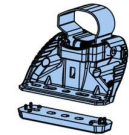

SA397U
PS178

R

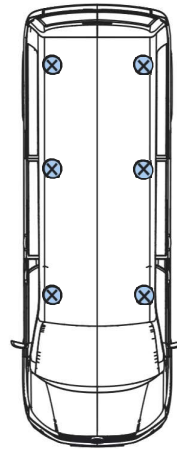

F

SA398U
PS178

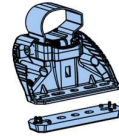

SA398U

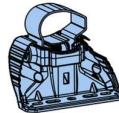

SA398U
PS178



4.

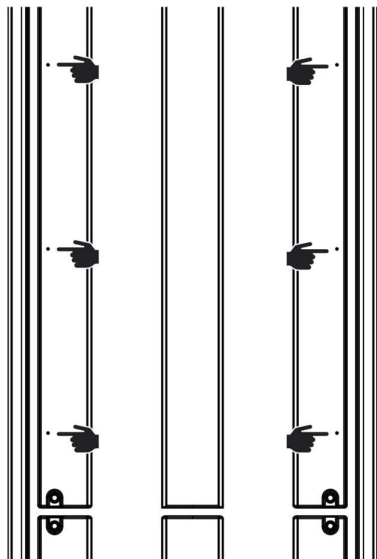

5.



1st - Ø 4mm
2nd - Ø 9mm



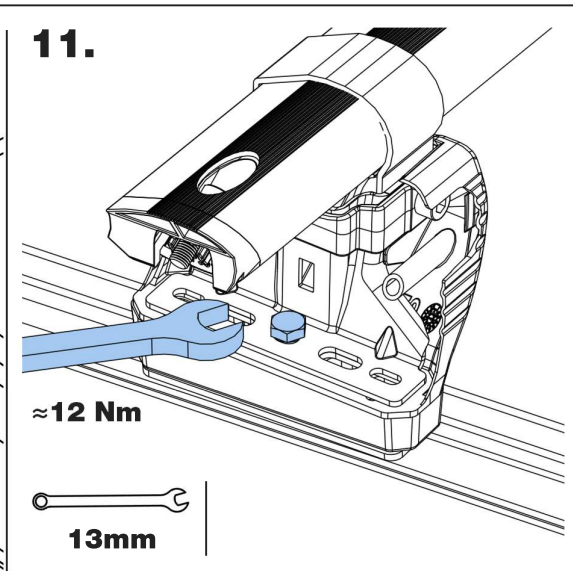
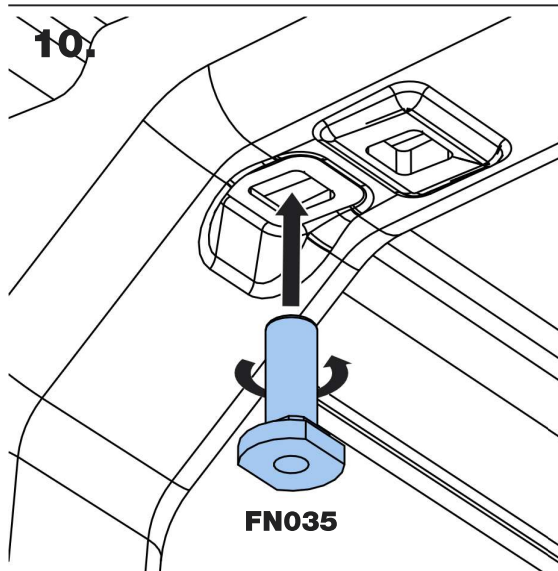
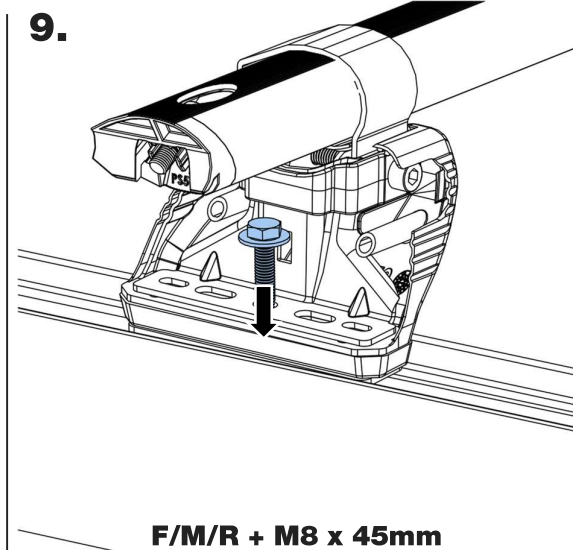
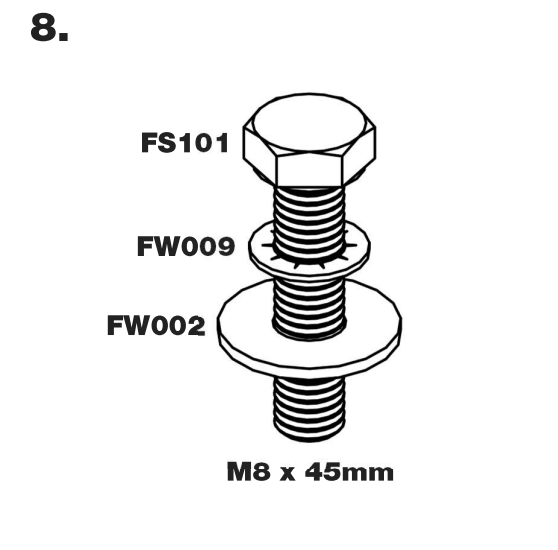
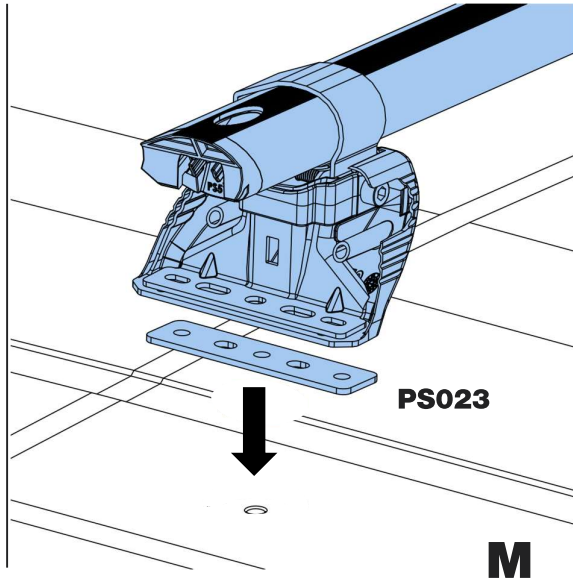
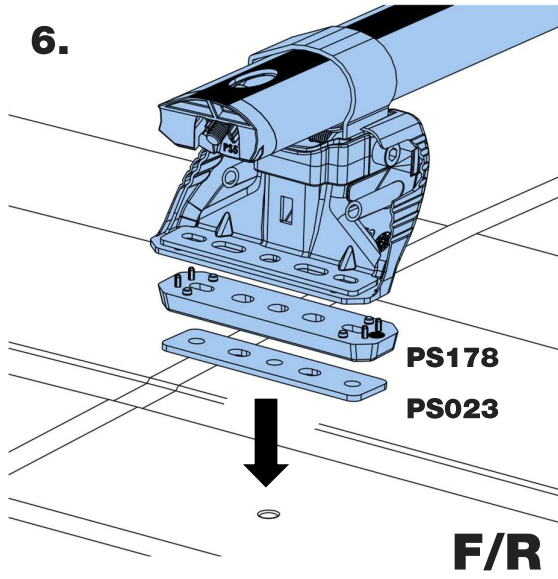

12.

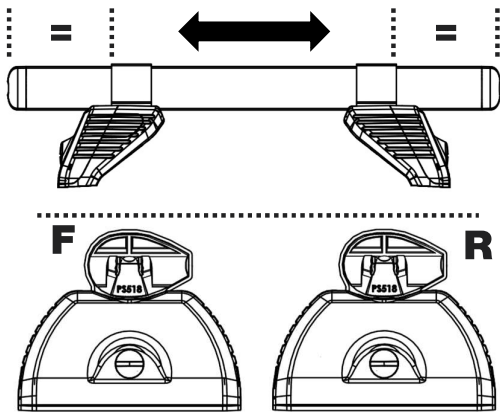

13.

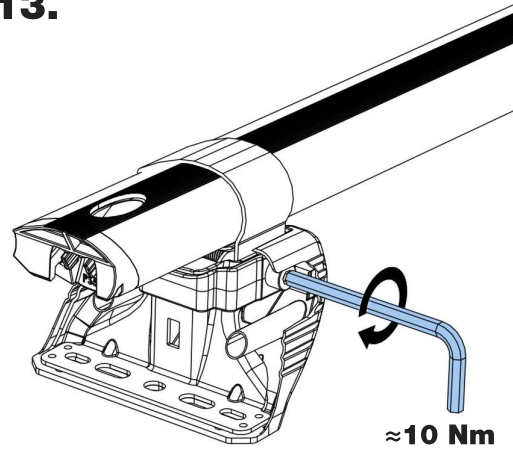

14.

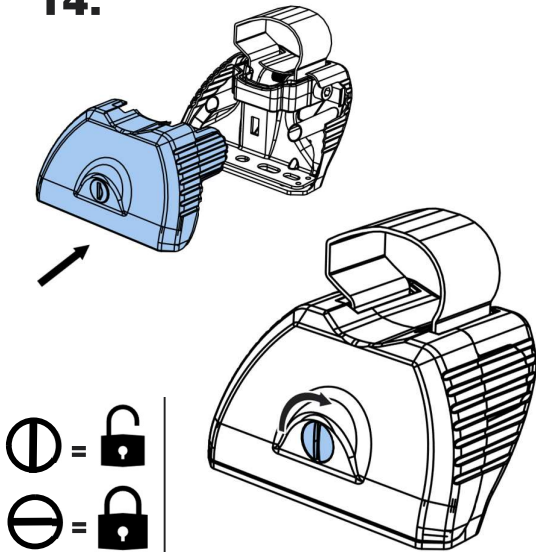

15.

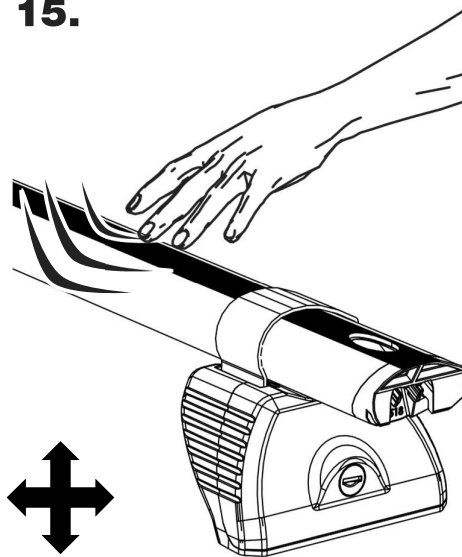

K619- Ford Transit Custom 2014- L1, H2 Twin Doors.

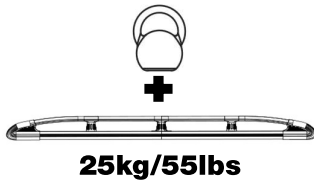

80kg Max

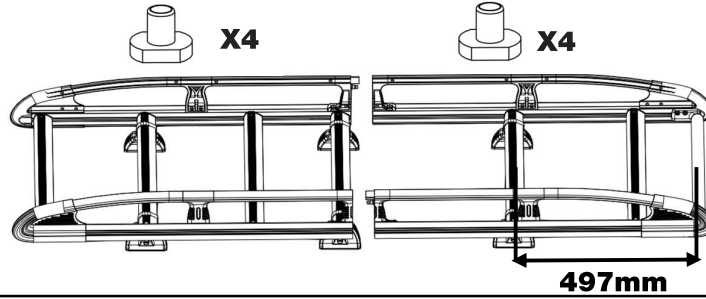
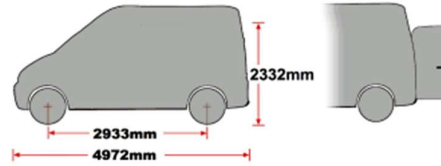

K620- Ford Transit Custom 2014- L2, H2 Twin Doors.

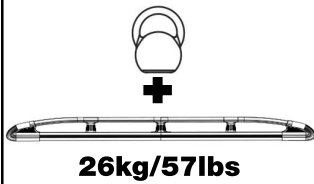

80kg Max

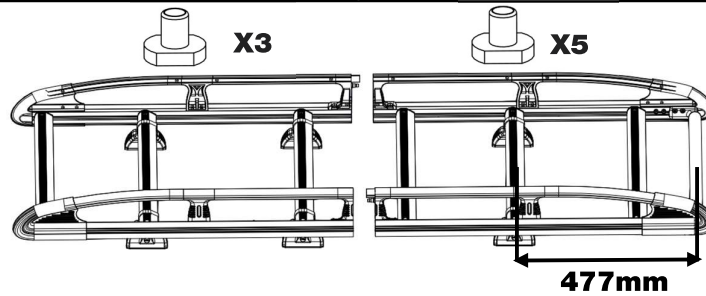
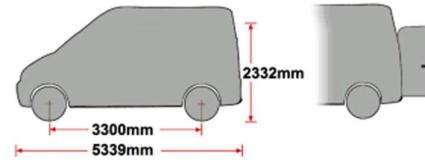

18.

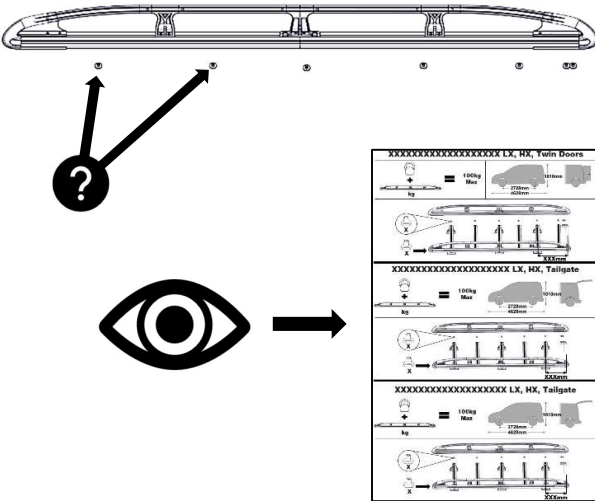

19.

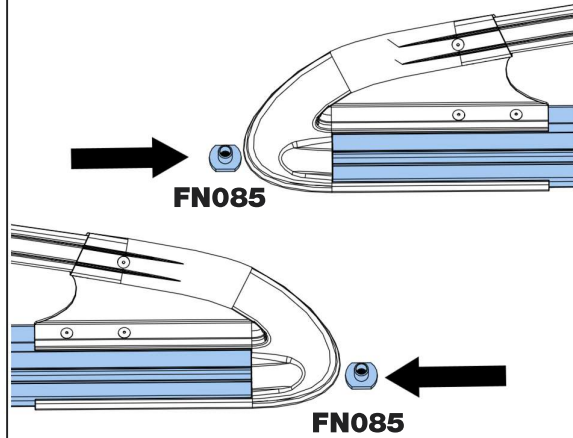

20.

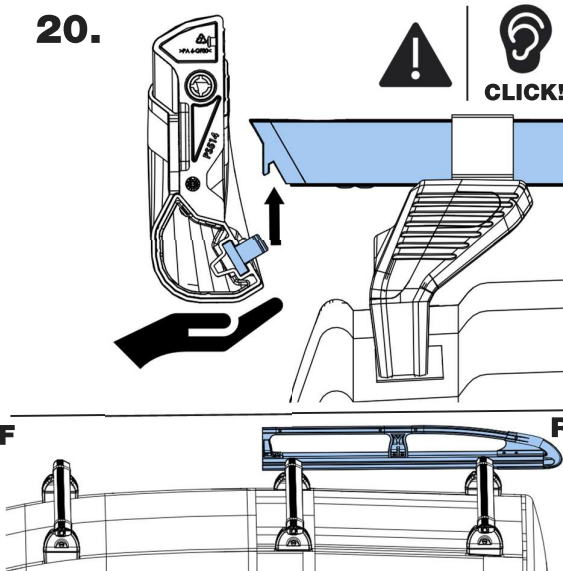

21.

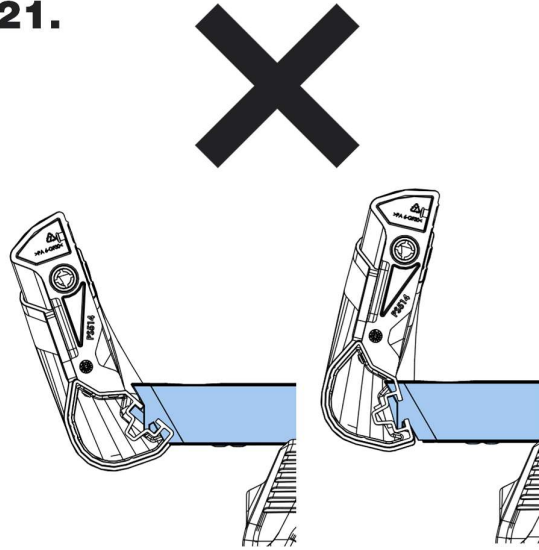

22.

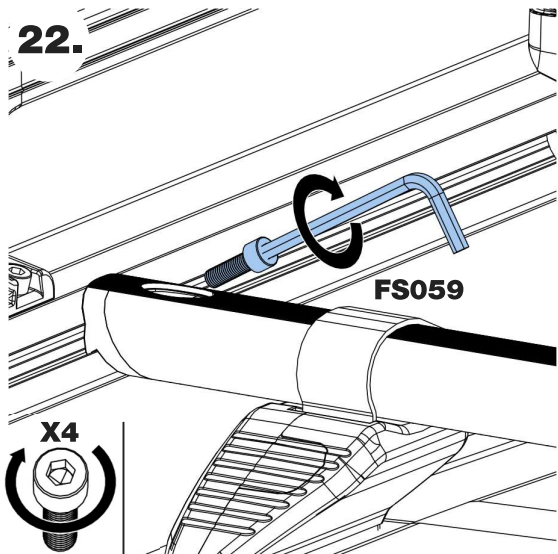

23.

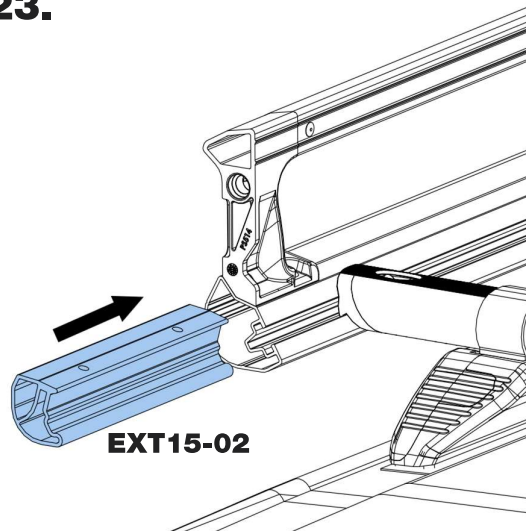

24.

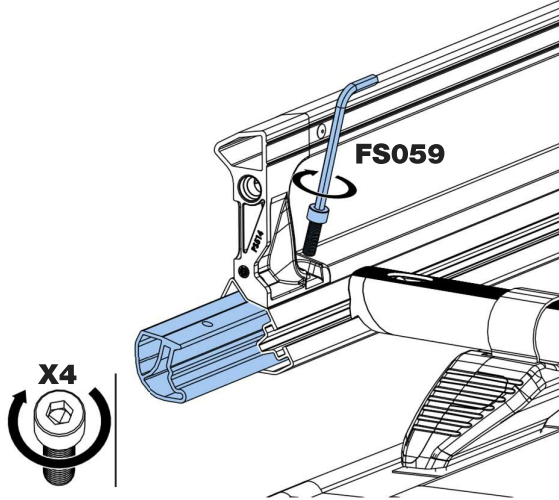

25.

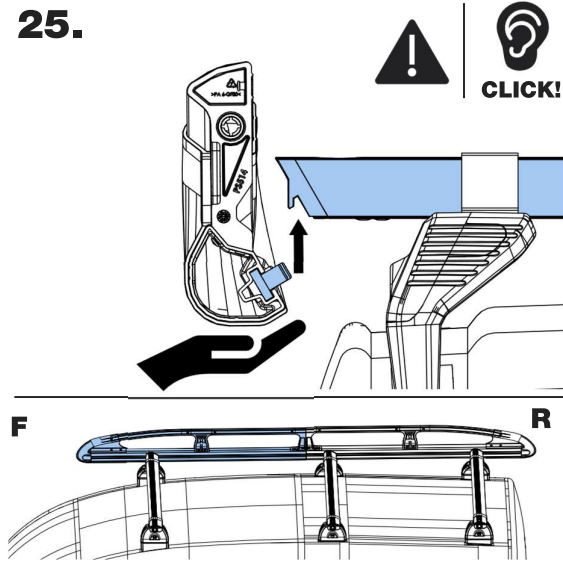

26.

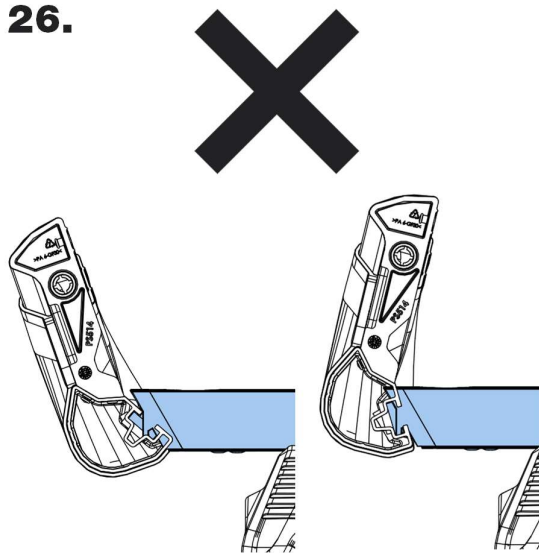

27.

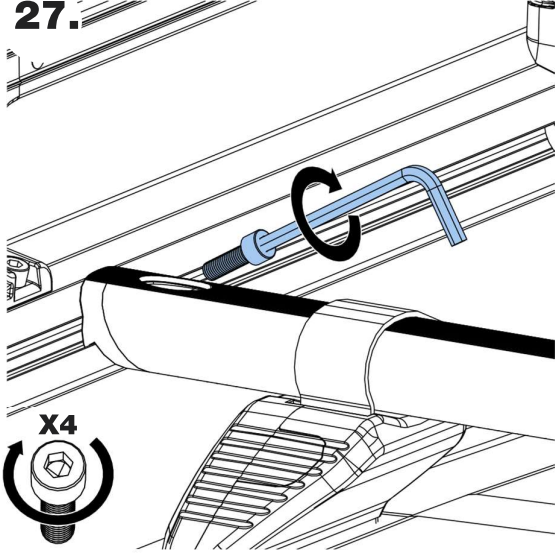

28.

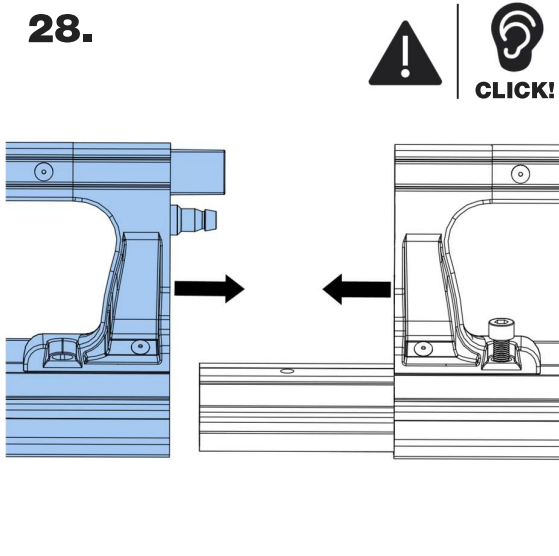

29.

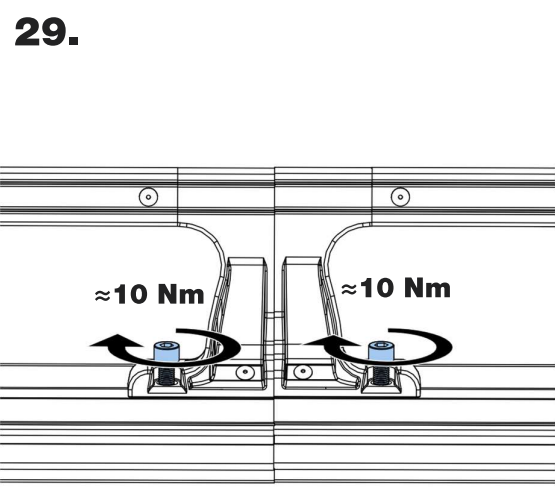

30.

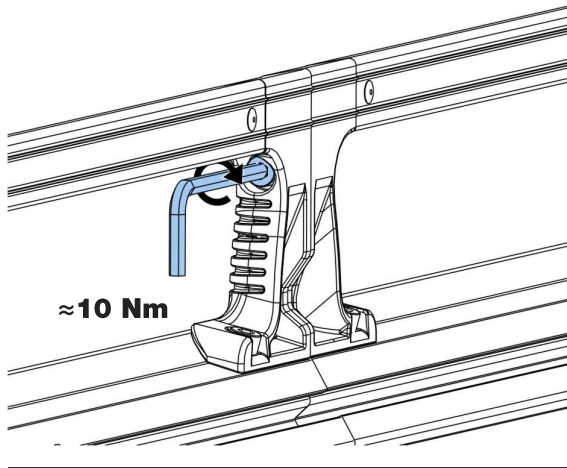

31.

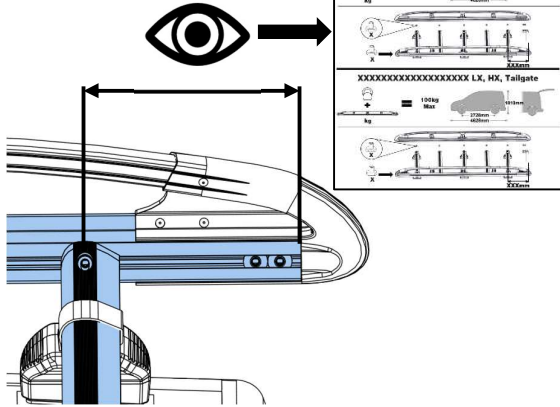

32.

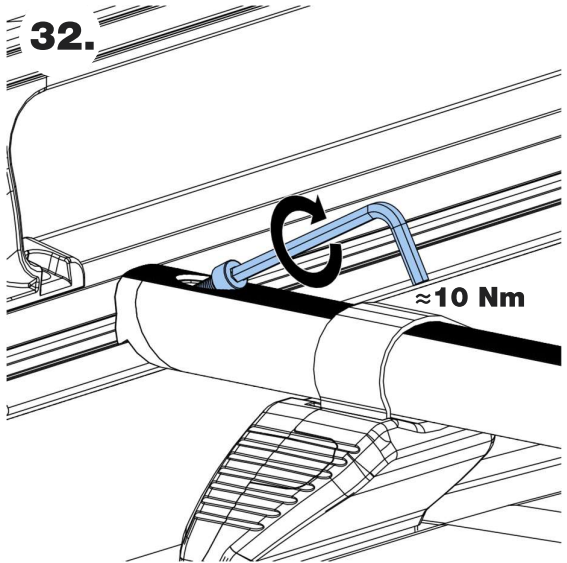

33.

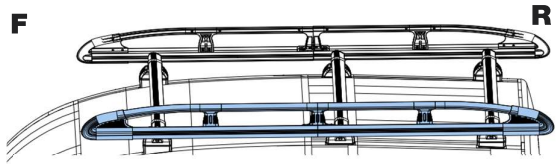
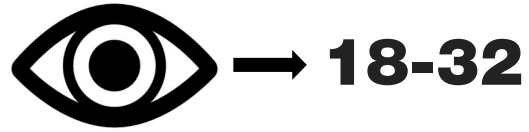

34.

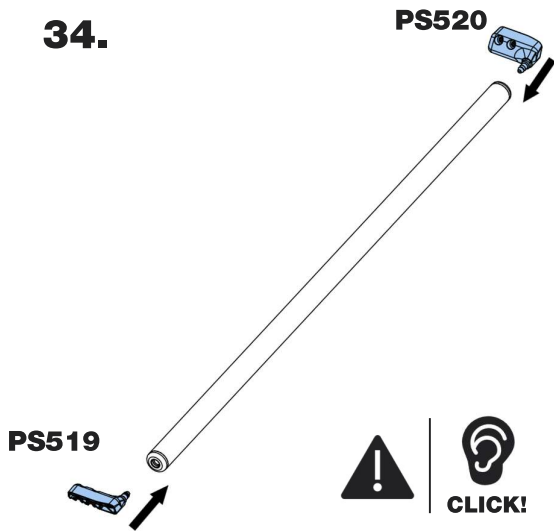

35.

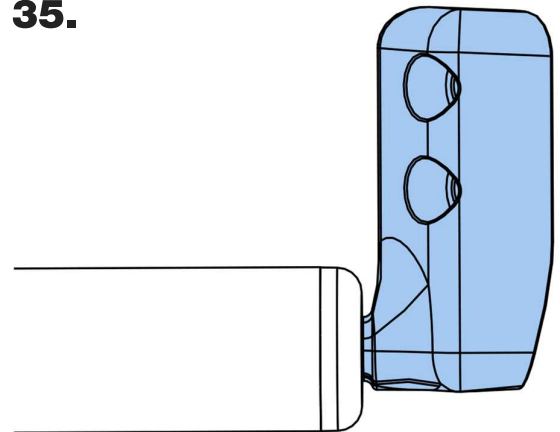

36.

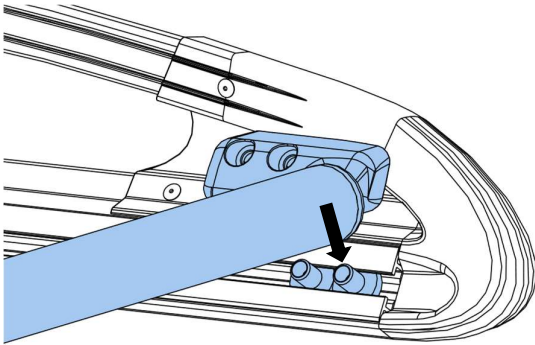

37.

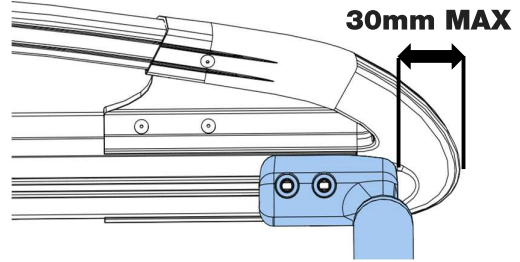

38.

A

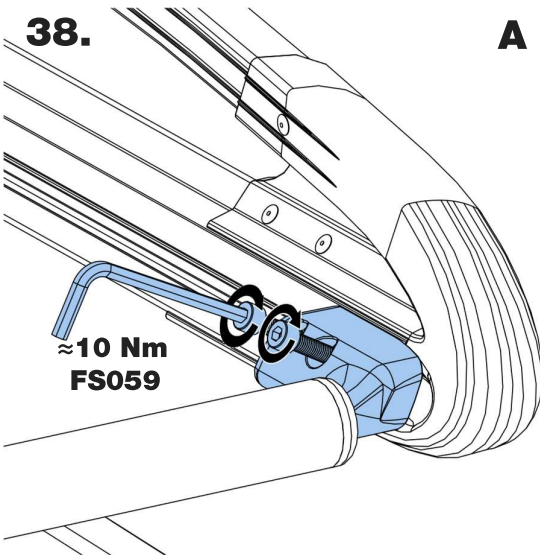

39.

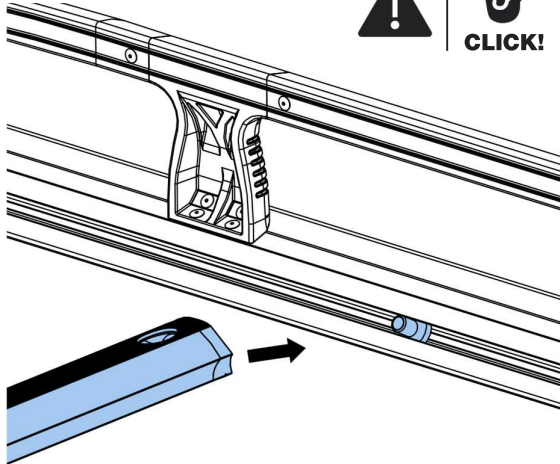

40.

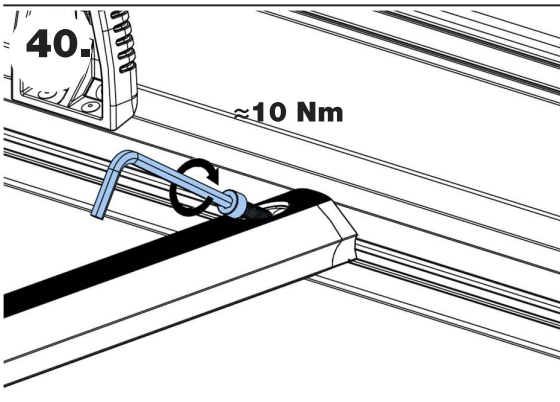

41.

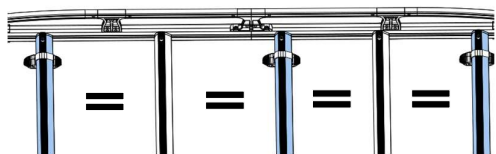
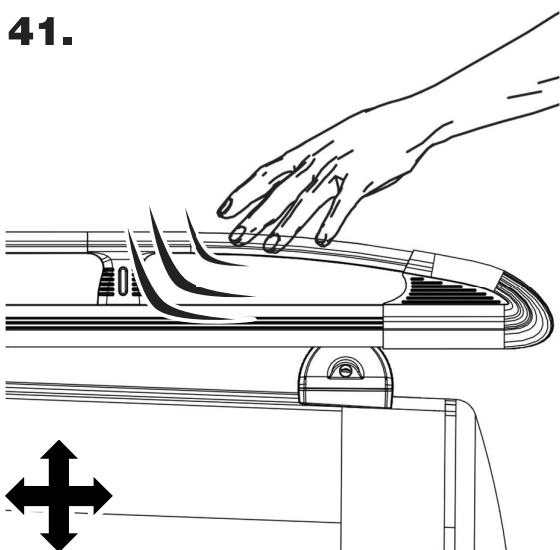

42.

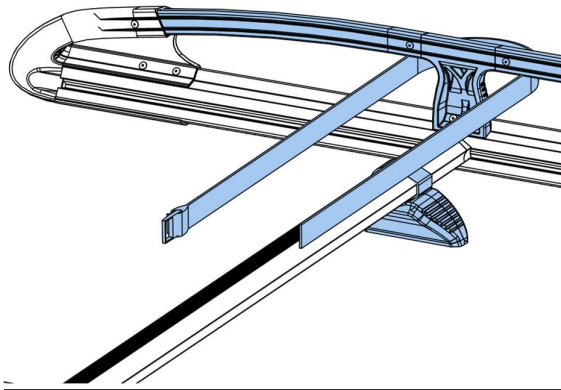

43.

