



04/2006 -

MERCEDES VOLKSWAGEN
SPRINTER 5T CRAFTER 5T

Skrzynia, podwójne koła

Skrzynia, podwójne koła

Cat. No.: M/024

e20

e20*94/20*0272*00

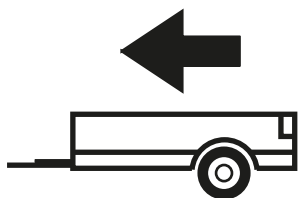

3 500kg

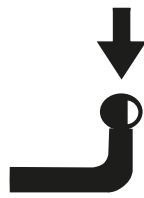

140kg

D = 20,20kN

D (kN) =



MAX kg

x

MAX kg

x 0,00981



MAX kg

+

MAX kg



IMIOLA HAK-POL

96-111 KOWIESY, CHOJNATA 23A, POLAND

tel. +48 46 831 73 31, fax +48 831 74 29

e-mail: office@imiola.pl, www.imiola.pl

Rys. 25a

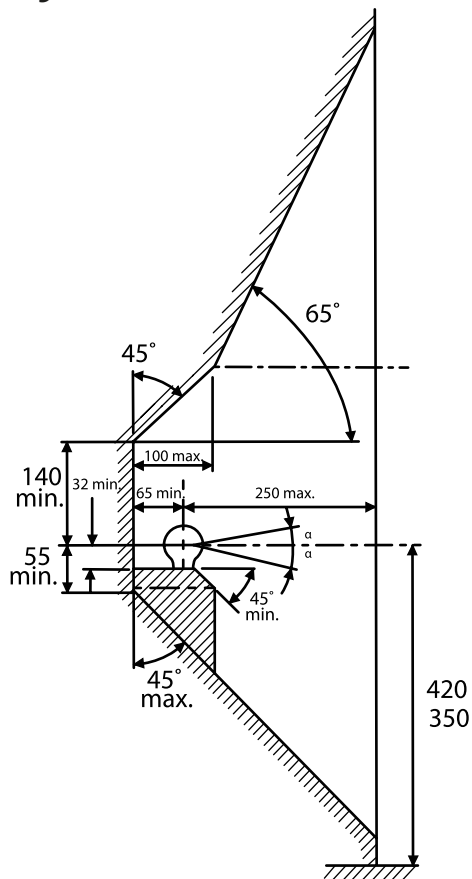

Rys. 25b

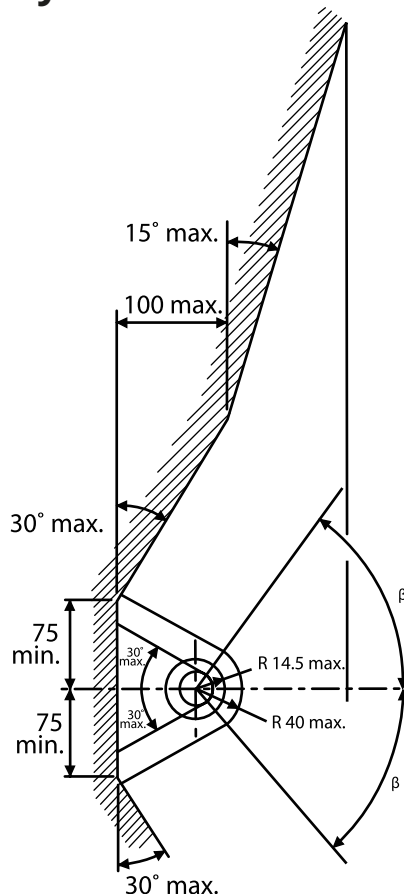

PL Należy zagwarantować przestrzeń swobodną według załącznika VII, rysunek 25a/b Regulaminu EKG ONZ 55.01 przy dopuszczalnym ciężarze całkowitym pojazdu.

GB The clearance specified in appendix VII, diagram 25a/b of Regulation No. 55.01 UN EU must be guaranteed at laden weight of the vehicle.

FR L'espace libre doit être garanti conformément à l'annexe VII, illustration de la réglementation 55.01 CE pour un poids total en charge autorisé du véhicule.

DE Der Freiraum nach Anhang VII, Abbildung 25a/b der Vorschriften 55.01 EG ist zu gew 25a/b abzuhalten bei zulässigem Gesamtgewicht des Fahrzeuges.

Moment skręcący dla śrub i nakrętek (8.8) Torgue settings for nuts and bolts (8.8)	
M8	25Nm
M10	55Nm
M12	85Nm
M14	135Nm
M16	195Nm









Nakrętka M12 ; Nut
 Podkl. spręż. 12,2 ; Spring Washer
 Podkl. okr. Ø36xØ13x3 ; Plain Washer

Śruba M12x120-8.8 ; Bolt

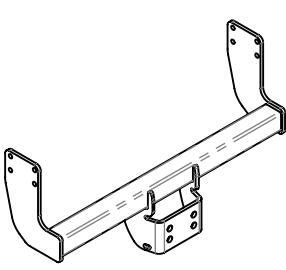
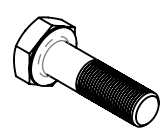
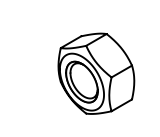
Śruba M12x120-8.8 ; Bolt

Nakrętka M16 ; Nut
 Podkl. spręż. 16,3 ; Spring Washer
 Podkl. okr. 17 ; Plain Washer

Nakrętka M10 ; Nut
 Podkl. spręż. 10,2 ; Spring Washer
 Podkl. okr. 10,5 ; Plain Washer
 Śruba M10x30-8.8 ; Bolt

	A	x1		M16x45	2
				M12x120	8
				M10x30	1
	M16	2			
	M12	8			
	M10	1			
	B	x1		Ø36xØ13x3	8
					C
10,5	1				
	16,3	2			
	12,2	8			
	10,2	1			

Nakrętka M12 ; Nut
 Podkł. spręż. 12,2 ; Spring Washer
 Podkł. okr. Ø36x Ø13x 3 ; Plain Washer

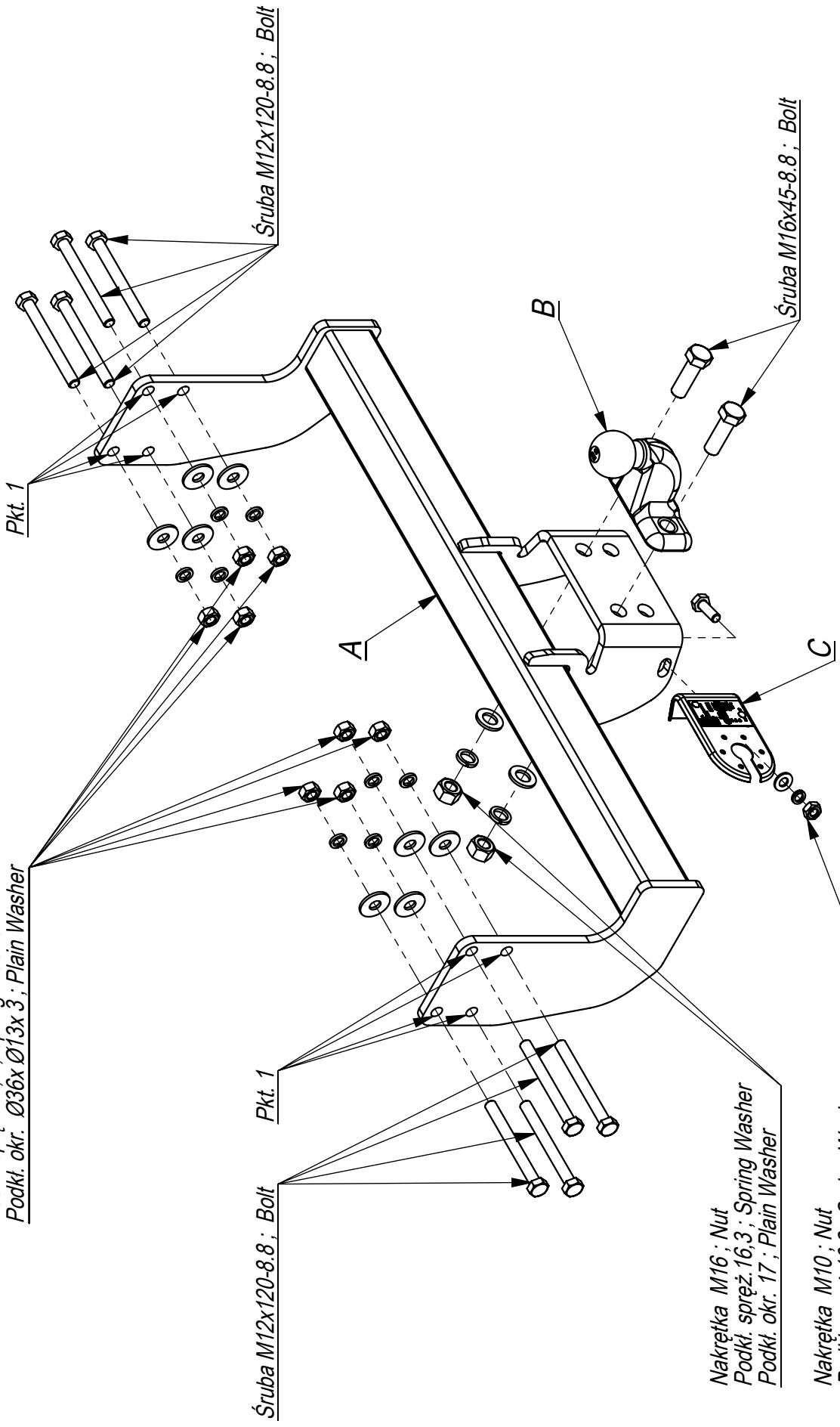

Śruba M12x120-8.8 ; Bolt

Śruba M12x120-8.8 ; Bolt

Pkt. 1

Pkt. 1

Nakrętka M16 ; Nut
 Podkł. spręż. 16,3 ; Spring Washer
 Podkł. okr. 17 ; Plain Washer

Nakrętka M10 ; Nut
 Podkł. spręż. 10,2 ; Spring Washer
 Podkł. okr. 10,5 ; Plain Washer
 Śruba M10x30-8.8 ; Bolt

Śruba M16x45-8.8 ; Bolt

Nr katalogowy Marka

M/024 Mercedes Sprinter 5T skrzynia, podwójne koła od 2006 ->
 VW Crafter 5T skrzynia, podwójne koła od 2006 ->



96-111 Kowiesy, Chojnata 23 A
 tel. +48 46 831 73 31

