



MERCEDES SPRINTER  
3,25; 3,665; 4,325; zabudowa  
VOLKSWAGEN CRAFTER  
stopień; poj. koła

04/2006 -

Cat. No. M/031

e20

e20\*94/20\*0675\*00

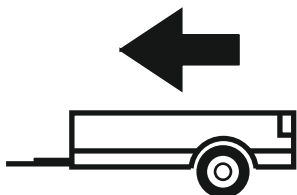

2800kg

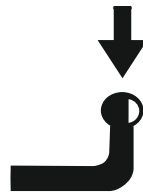

100kg

**D** = 15,24kN

**D (kN) =**



MAX kg x MAX kg

x 0,00981



MAX kg + MAX kg

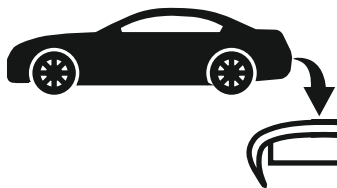

IMIOLA HAK-POL

96-111 KOWIESY, CHOJNATA 23A, POLAND

Tel. + 48 46 831 73 31, fax +48 831 74 29

e-mail: office@imiola.pl, www.imiola.pl

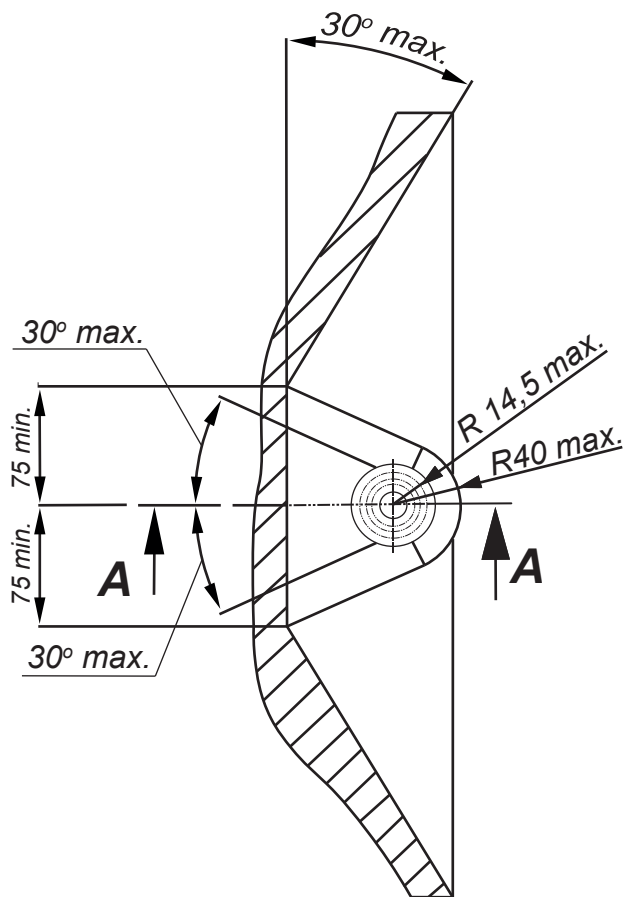

## PRZEKRÓJ A-A

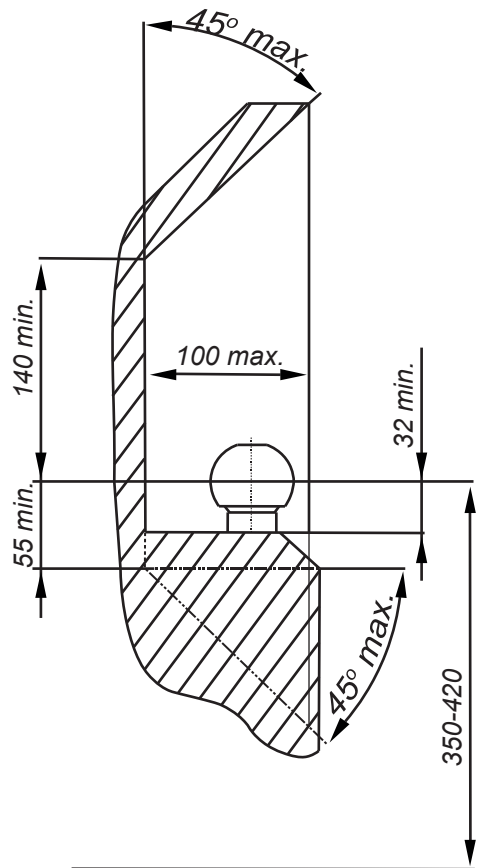

**PL** Należy zagwarantować przestrzeń swobodną według załącznika VII, rysunek 25a/b Regulaminu EKG ONZ 55.01 przy dopuszczalnym ciężarze całkowitym pojazdu.

**F** L'espace libre doit être garanti conformément à l'annexe VII, illustration de la réglementation 55.01 CE pour un poids total en charge autorisé du véhicule.

**GB** The clearance specified in appendix VII, diagram 25a/b of Regulation No. 55.01 UN EU must be guaranteed at laden weight of the vehicle.

**D** Der Freiraum nach Anhang VII, Abbildung 25a/b der Vorschriften 55.01 EG ist zu gew 25a/b abzustellen bei zulässigem Gesamtgewicht des Fahrzeuges.

Moment skręcający dla śrub i nakrętek (8.8) Torgue settings for nuts and bolts (8.8)	
M8	25Nm
M10	55Nm
M12	85Nm
M14	135Nm
M16	195Nm

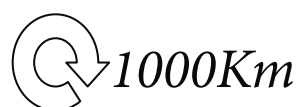

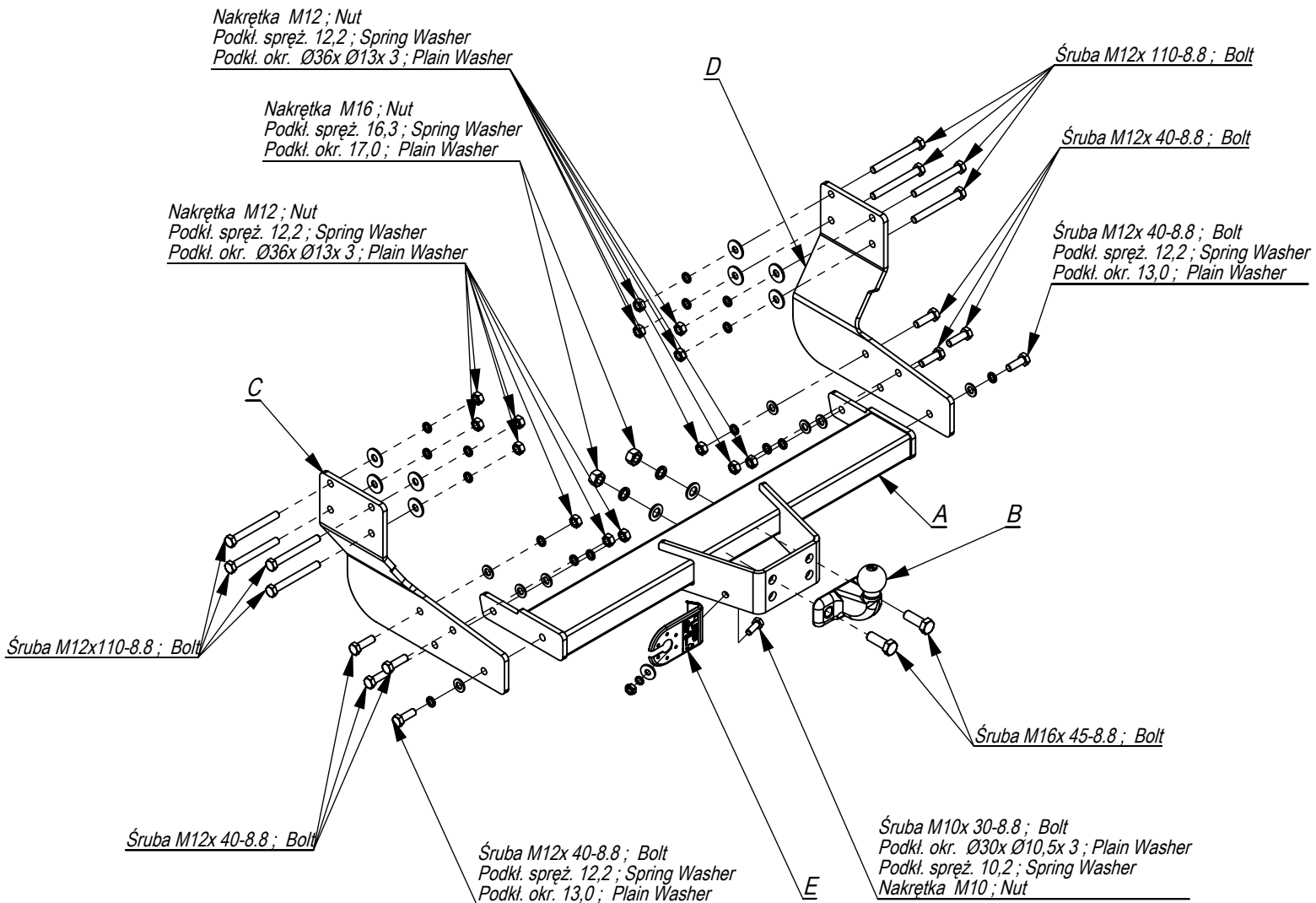

	A	x1		M16x45	2
				M12x110	8
				M12x40	8
				M10x25	1
	B	x1		M16	2
				M12	14
				M10	1
	C	x1		Ø36xØ13x3	8
				Ø30xØ10,5x3	1
	D	x1		17	2
				13	8
	E	x1		16,3	2
				12,2	16
				10,2	1

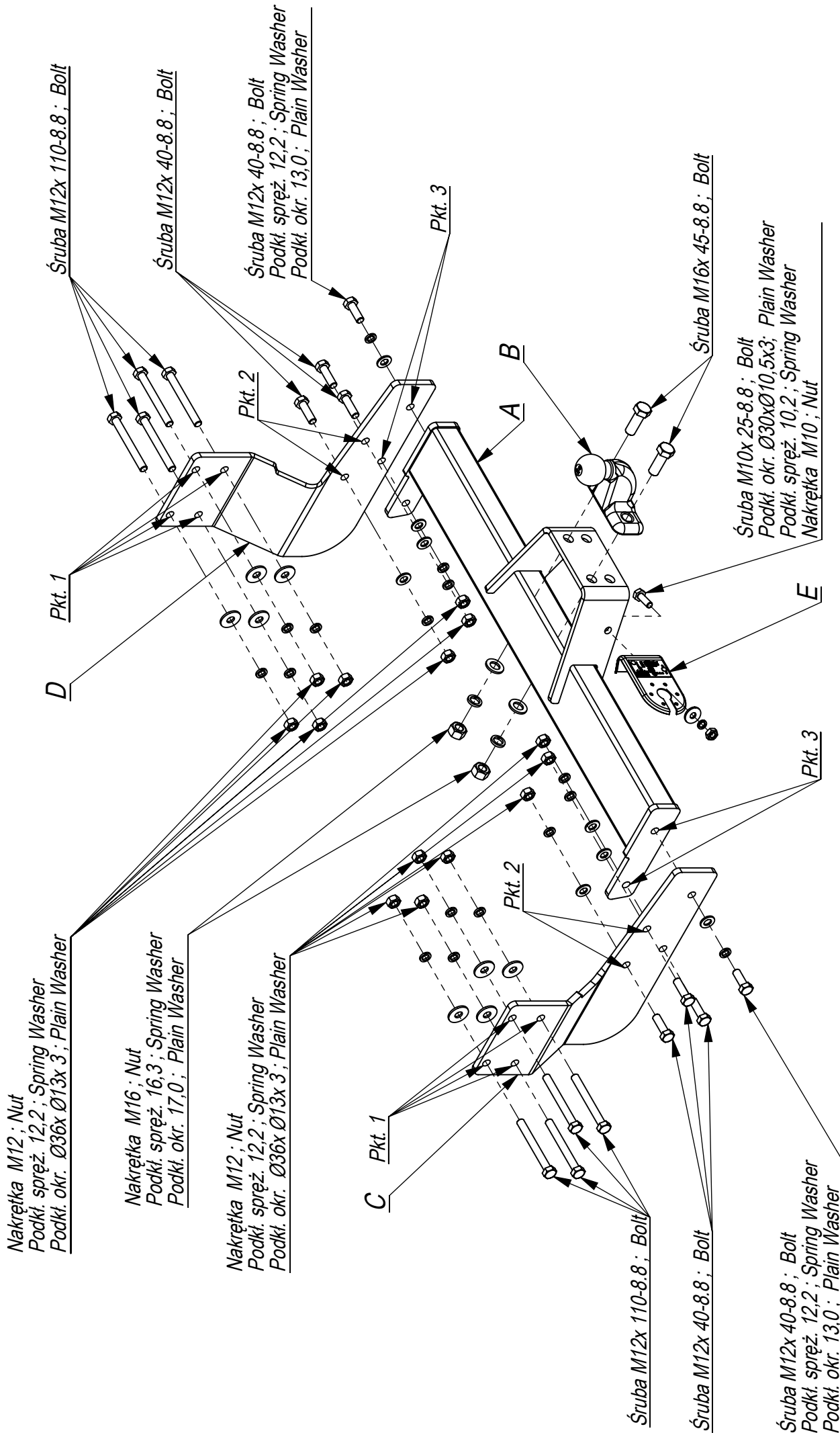

96-111 Kowiesy, Chojnata 23 A  
tel. +48 46 831 73 31

Nr katalogowy  
**M/031**

Marka  
**Mercedes Sprinter  
Volkswagen Crafter**

3,25; 3,665; 4,325;  
zabudowa,  
stopień; poj. kola

od 04/2006 ->  
od 04/2006 ->

Nr katalogowy  
**M/031**

Marka

**Mercedes Sprinter  
Volkswagen Crafter**

3,25; 3,665; 4,325;  
zabudowa,  
stopień; poj. kola

od 04/2006 ->  
od 04/2006 ->

- Do technologicznych otworów montażu zaczeu znajdujących się w ramie (pkt. 1) przykręcić lekko wsporniki zaczeu C i D śrubami M12x110 8.8 z nakładkami.
- Do wsporników C i D przykręcić lekko belkę zaczeu A śrubami M12x40 8.8 (pkt 3).
- Poprzez otwory w elementach zaczeu C i D (pkt 2) wykonać otwory  $\varnothing$  12,5 w uchwytach stopnia i skręcić śrubami M12x40 8.8.
- Do belki zaczeu A przykręcić kulę zaczeu B śrubami M16x45 8.8.
- Dokręcić śruby z momentem siły wg tabeli.
- Podłączyć instalację elektryczną.

- Screw slightly the supporters C and D to the technological fitting tow bar holes in the chassis (point 1) with bolts M12x110 8.8 using the plates.
- Screw slightly the main bar A to the elements C and D with bolts M12x40 8.8 (pkt 3).
- Drill the holes  $\varnothing$  12,5 in the handles of the footboard through the holes in the elements C and D (point 2) and screw with bolts M12x40 8.8.
- Fix the ball B to the main bar A with bolts M16x45 8.8.
- Tighten all the bolts according to the torque setting- see the table.
- Connect the electric wires.

- Dévisser la roue de rechange.
- A travers les trous dans le cadron (point 1) visser légèrement les éléments C et D aux bords des longerons, en utilisant les boulons M12x110 8.8 et les rondelles.
- Serrer la poutre du crochet A aux éléments C avec les boulons M12x40 8.8 (point 2 et 3).
- Visser le crochet d'attelage a la poutre du crochet A en utilisant les boulons M16x45 8.8 (point 4).
- Serrer tous les boulons avec un couple de serrage selon tableau.
- Raccorder le circuit électrique.
- Monter la roue de rechange.

- An die vom Werk aus vorhandenen im Gestell Montagestellen (1) die Gestellstützen C und D mit den Schrauben M12x110 8.8 mit den Unterlegscheiben locker anschrauben.
- An die Stützen C und D den Querbalken A mit den Schrauben M12x40 8.8 (Punkt 3) locker anschrauben.
- Durch die Öffnungen in den Tragteilen C und D (Punkt 2) die Bohrungen  $\varnothing$ 12,5 in den Trittbrettgriffen ausführen und mit den Schrauben M12x40 8.8 verschrauben.
- An den Querbalken A die Kugel D mit den Schrauben M16x45 8.8 anschrauben.
- Alle Schrauben mit dem in der Tabelle angegebenen Drehmoment festziehen.
- Die Elektroinstallation anschließen.

