

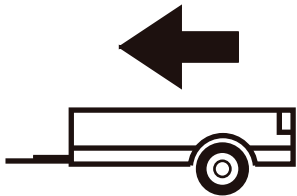

Cat. No. N/054

| | |
|--------------------------------------|--------|
| NISSAN NAVARA King Cab (D23) NP300 | 07/14- |
| NISSAN NAVARA Double Cab (D23) NP300 | 01/15- |
| RENAULT ALASKAN | 10/16- |
| MERCEDES X-CLASS | 09/17- |

E20 E20*55R01/07*005916*00



3519kg



140kg

D = 16,83kN

D (kN) =



MAX kg

x

MAX kg

x 0,00981



MAX kg

+

MAX kg



IMIOLA HAK-POL

96-111 KOWIESY, CHOJNATA 23A, POLAND

Tel. + 48 46 831 73 31, fax +48 831 74 29

e-mail: office@imiola.pl, www.imiola.pl

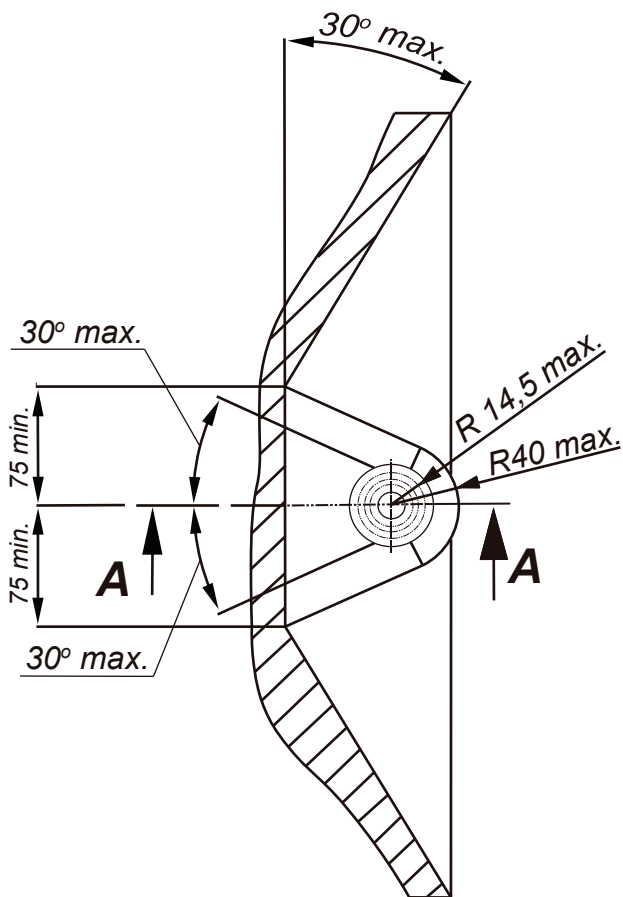

PRZEKRÓJ A-A

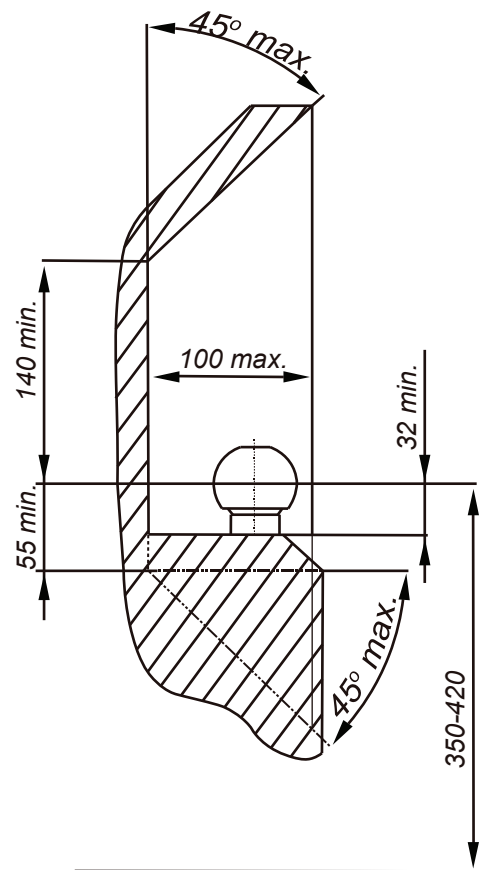

PL Należy zagwarantować przestrzeń swobodną według załącznika VII, rysunek 25a/b Regulaminu EKG ONZ 55.01 przy dopuszczalnym ciężarze całkowitym pojazdu.

F L'espace libre doit être garanti conformément à l'annexe VII, illustration de la réglementation 55.01 CE pour un poids total en charge autorisé du véhicule.

GB The clearance specified in appendix VII, diagram 25a/b of Regulation No. 55.01 UN EU must be guaranteed at laden weight of the vehicle.

D Der Freiraum nach Anhang VII, Abbildung 25a/b der Vorschriften 55.01 EG ist zu gewährleisten bei zulässigem Gesamtgewicht des Fahrzeuges.

Moment skrecający dla śrub i nakrętek (8.8) Torque settings for nuts and bolts (8.8)

| | |
|-----------|-------------|
| M8 | 25Nm |
| M10 | 55Nm |
| M12 | 85Nm |
| M14 | 135Nm |
| M16 | 195Nm |



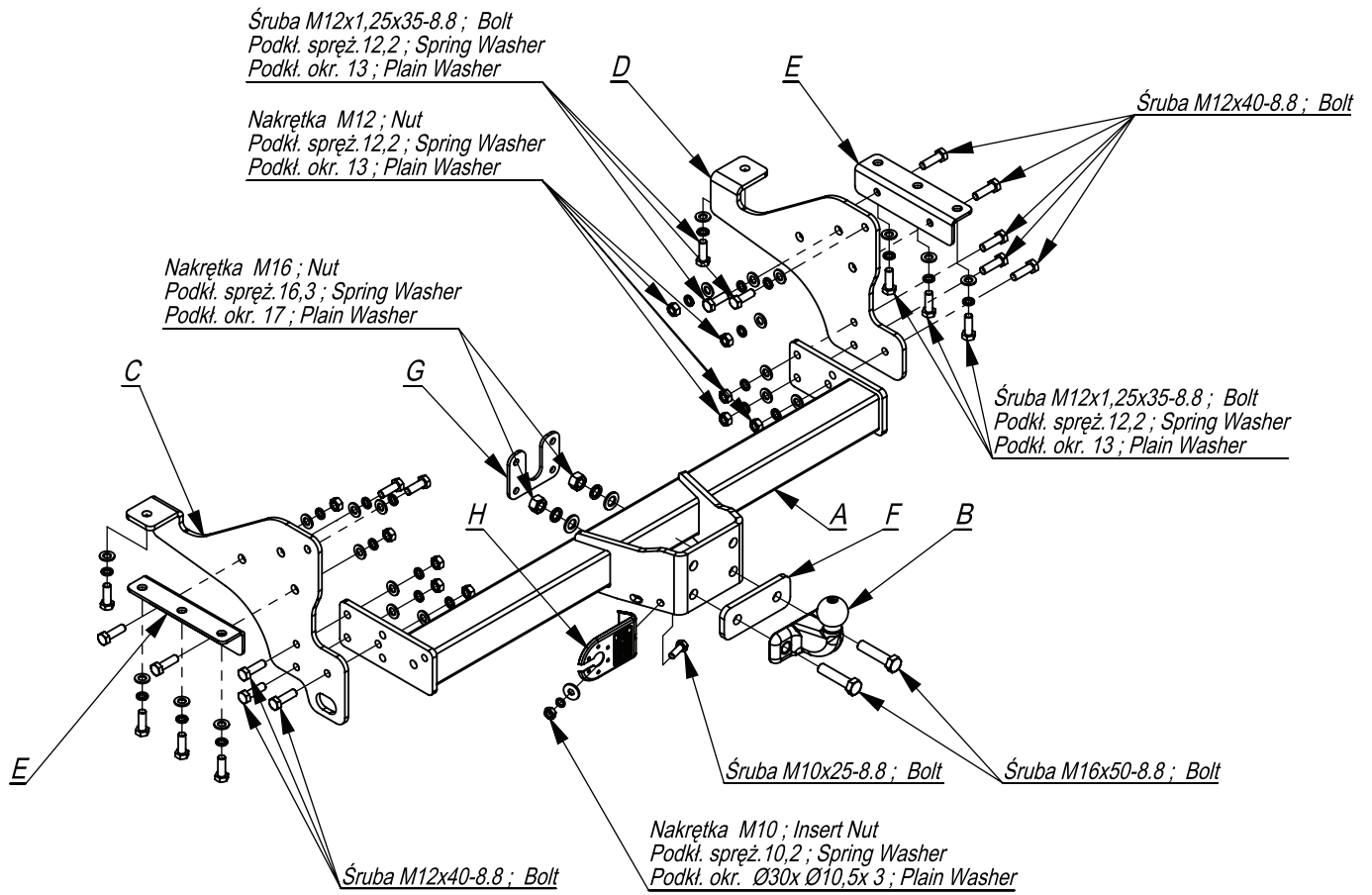

| | | | | | |
|--|---|----|--|-------------|----|
| | A | x1 | | M16x50 | 2 |
| | | | | M12x40 | 10 |
| | | | | M12x1,25x35 | 12 |
| | | | | M10x25 | 1 |
| | B | x1 | | M16 | 2 |
| | | | | M12 | 10 |
| | | | | M10 | 1 |
| | C | x2 | | Ø30xØ10,5x3 | 1 |
| | | | | 17 | 2 |
| | D | x1 | | 13 | 22 |
| | | | | 16,3 | 2 |
| | E | x2 | | 12,2 | 22 |
| | | | | 10,2 | 1 |
| | F | x1 | | | |
| | G | x1 | | | |
| | H | x1 | | | |

Tylko dla
 kuli z 4 otworami
 Only for
 4 holes flange ball

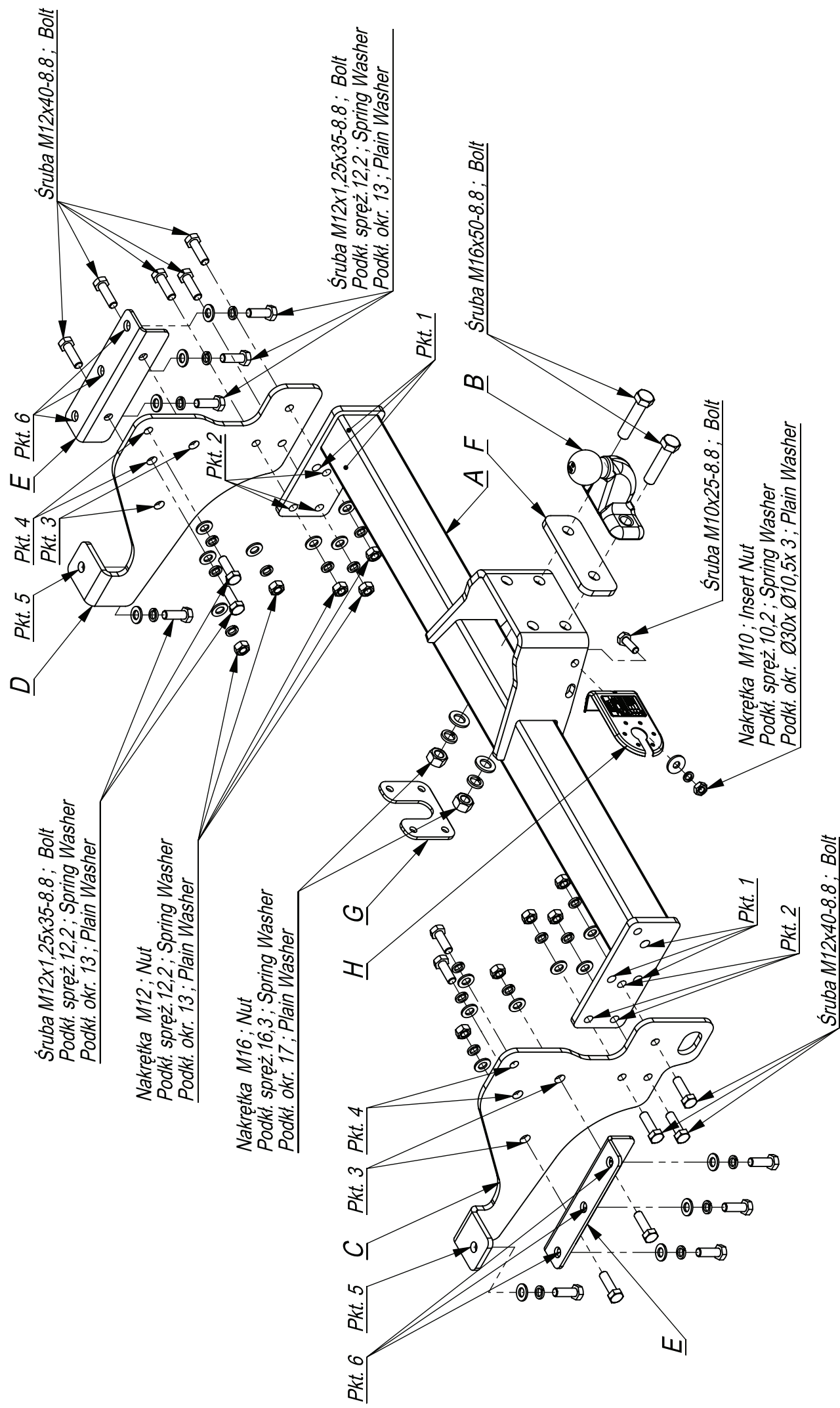

Śruba M12x1,25x35-8.8 ; Bolt
Podkt. spręż. 12,2 ; Spring Washer
Podkt. okr. 13 ; Plain Washer

Nakrętka M12 ; Nut
Podkt. spręż. 12,2 ; Spring Washer
Podkt. okr. 13 ; Plain Washer

Nakrętka M16 ; Nut
Podkt. spręż. 16,3 ; Spring Washer
Podkt. okr. 17 ; Plain Washer

Śruba M12x1,25x35-8.8 ; Bolt
Podkt. spręż. 12,2 ; Spring Washer
Podkt. okr. 13 ; Plain Washer

Śruba M16x50-8.8 ; Bolt

Śruba M10x25-8.8 ; Bolt

Nakrętka M10 ; Insert Nut
Podkt. spręż. 10,2 ; Spring Washer
Podkt. okr. Ø30x Ø10,5x 3 ; Plain Washer

Śruba M12x40-8.8 ; Bolt

| Nr katalogowy | Marka | Model | Wzrost |
|---------------|----------|-------------------------------|----------------|
| N/054 | Nissan | NP300 Navara King Cab (D23) | od 2014 - > |
| | Nissan | NP300 Navara Double Cab (D23) | od 2015 - > |
| | Renault | Alaskan | od 10/2016 - > |
| | Mercedes | X Class | od 09/2017 - > |

