



Cat. No. **R/024**

RENAULT TRAFIC

2001-2014

OPEL VIVARO

2001-07/2014

NISSAN PRIMASTAR

09/2002-2014

e20

e20*94/20*0014*00

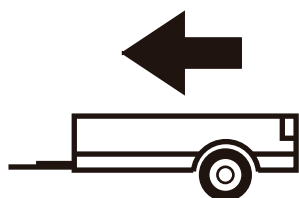

2000kg

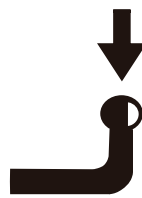

80kg

D = 11,70kN

D (kN) =



MAX kg

x

MAX kg

x 0,00981



MAX kg

+

MAX kg



IMIOLA HAK-POL

96-111 KOWIESY, CHOJNATA 23A, POLAND

Tel. + 48 46 831 73 31, fax +48 831 74 29

e-mail: office@imiola.pl, www.imiola.pl

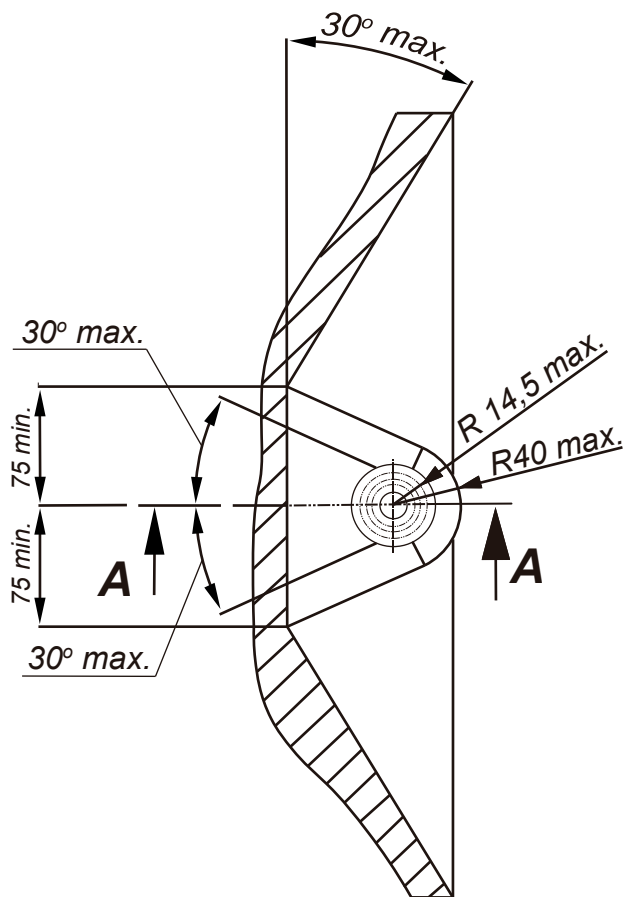

PRZEKRÓJ A-A

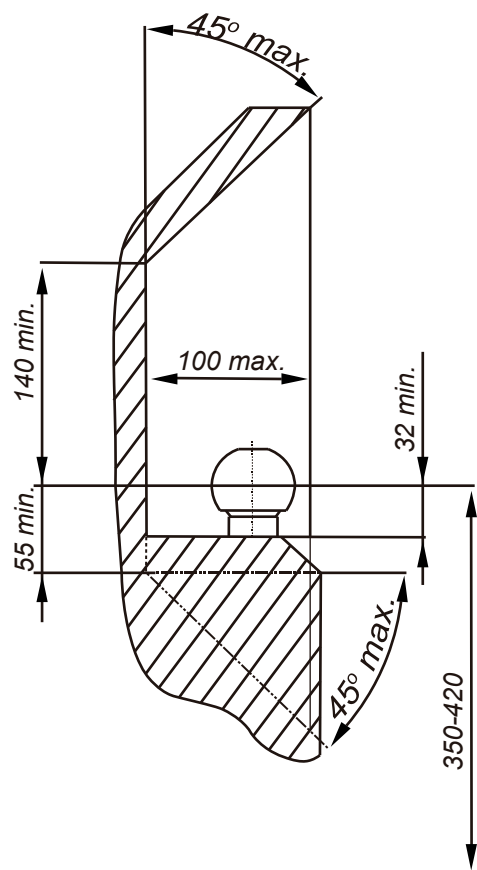

PL Należy zagwarantować przestrzeń swobodną według załącznika VII, rysunek 25a/b Regulaminu EKG ONZ 55.01 przy dopuszczalnym ciężarze całkowitym pojazdu.

F L'espace libre doit être garanti conformément à l'annexe VII, illustration de la réglementation 55.01 CE pour un poids total en charge autorisé du véhicule.







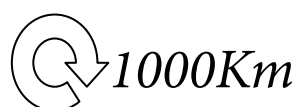

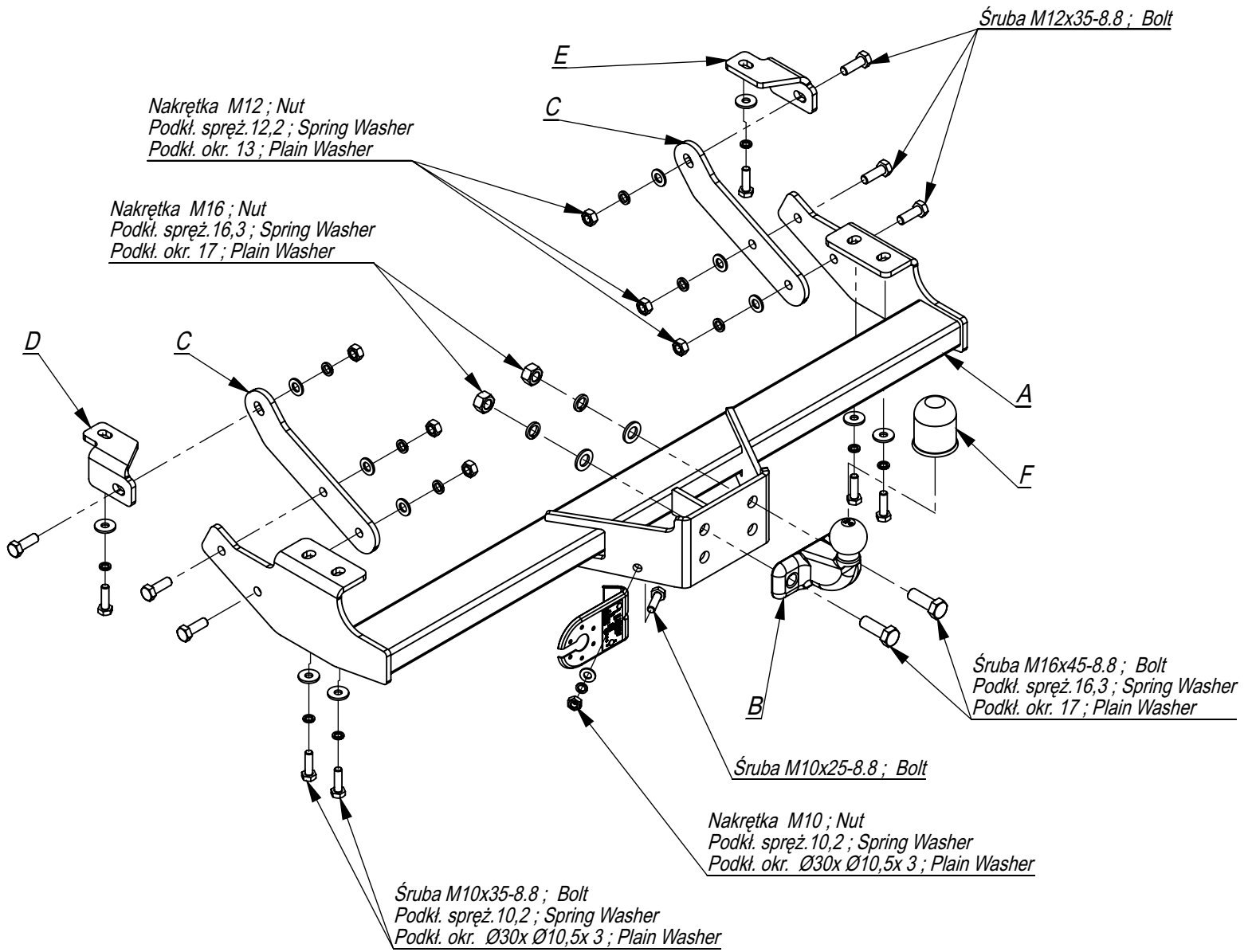

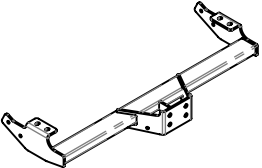
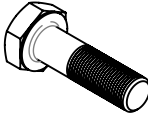
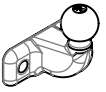
GB The clearance specified in appendix VII, diagram 25a/b of Regulation No. 55.01 UN EU must be guaranteed at laden weight of the vehicle.

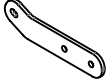
D Der Freiraum nach Anhang VII, Abbildung 25a/b der Vorschriften 55.01 EG ist zu gewährleisten bei zulässigem Gesamtgewicht des Fahrzeuges.

Moment skręcający dla śrub i nakrętek (8.8) Torque settings for nuts and bolts (8.8)	
M8	25Nm
M10	55Nm
M12	85Nm
M14	135Nm
M16	195Nm





	A	x1		M16x45	2
				M12x35	6
				M10x35	6
				M10x25	1
	B	x1		M16	2
				M12	6
				M10	1
	C	x2		Ø30xØ10,5x3	7
	D	x1		17	2
	E	x1		12,2	6
	F	x1		17	2
				12,2	6
				10,2	7

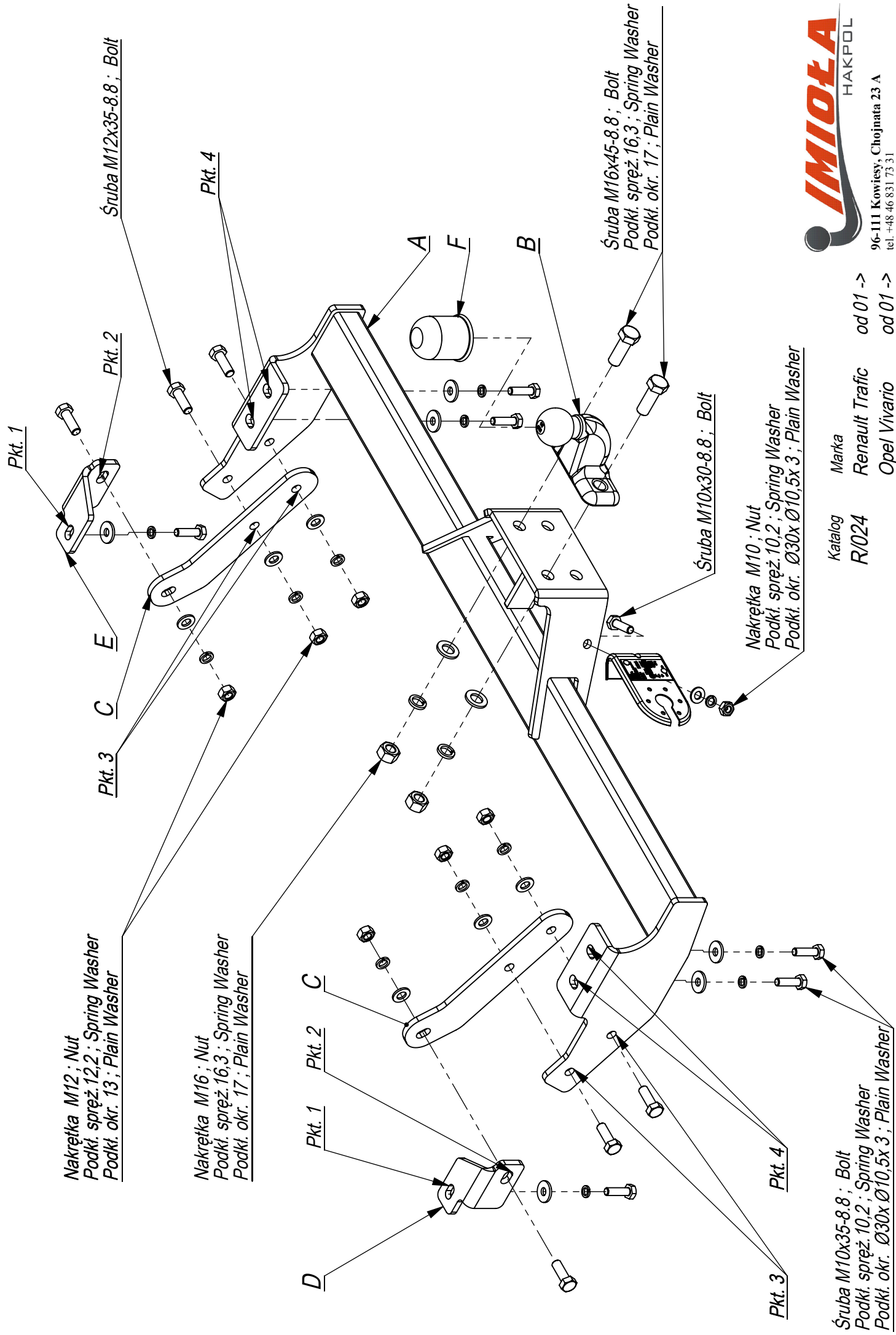

Nakrętka M12; Nut
 Podkl. spręż. 12,2; Spring Washer
 Podkl. okr. 13; Plain Washer

Nakrętka M16; Nut
 Podkl. spręż. 16,3; Spring Washer
 Podkl. okr. 17; Plain Washer

Pkt. 1
 Pkt. 2
 Pkt. 3
 Pkt. 4

Śruba M12x35-8.8; Bolt

Śruba M16x45-8.8; Bolt
 Podkl. spręż. 16,3; Spring Washer
 Podkl. okr. 17; Plain Washer

Śruba M10x30-8.8; Bolt

Nakrętka M10; Nut
 Podkl. spręż. 10,2; Spring Washer
 Podkl. okr. Ø30xØ10,5x 3; Plain Washer

Śruba M10x35-8.8; Bolt
 Podkl. spręż. 10,2; Spring Washer
 Podkl. okr. Ø30xØ10,5x 3; Plain Washer



96-111 Kowiesy, Chojnata 23 A
 tel. +48 46 831 73 31

Katalog	Marka	od 01 ->
R/024	Renault Trafic	od 01 ->
	Opel Vivario	

- Belkę zaczepu A oraz elementy zaczepu D i E przykręcić luźno śrubami M10x35 8.8 do fabrycznych punktów montażu zaczepu znajdujących się w podłużnicach samochodu (pkt 1 i 4).
- Elementami zaczepu C połączyć luźno belkę zaczepu A z elementami zaczepu D i E śrubami M12x35 8.8 (pkt 2 i 3).
- Przykręcić kulę zaczepu do belki zaczepu A śrubami M16x45 8.8.
- Dokręcić wszystkie śruby z momentem wg tabeli.
- Podłączyć instalację elektryczną.

- Screw slightly the main bar A and elements D, E to the technological tow bar fitting points in the metal clamps with bolts M10x35 8.8 (point 1 and 4).
- Connect loosely the main bar A with the elements D and E using the elements C with bolts M12x35 8.8 (point 2 and 3).
- Fix the ball to the main bar A with bolts M16x45 8.8.
- Tighten all the bolts according to the torque setting- see the table.
- Connect the electric wires

- Serrer legerement la traverse d'attache A et les éléments de fixation D et E par les boulons M10x35 8.8 aux points de fixation de longerons de voiture (point 1 et 4) prévus par le fabricant.
- Pointer les éléments de fixation C de la traverse d'attache A aux éléments D et E par les boulons M12x35 8.8 (point 2 et 3).
- Visser le crochet d'attelage a la traverse d'attache par les boulons M16x45 8.8.
- Serrer tous les boulons avec un couple de serrage selon tableau.
- Raccorder le circuit électrique.

- Den Querbalken A und die Tragteile D und E mit den Schrauben M10x35 8.8 an die vom Werk aus in den Längsträgern vorhandene Montagepunkte (Punkt 1,4) locker anschrauben.
- Mit den Tragteilen C den Querbalken A mit den Tragteilen D und E mit den Schrauben M12x35 8.8 (Punkt 2,3) locker verbinden.
- Die Kugel an den Querbalken A mit den Schrauben M16x45 8.8 anschrauben.
- Alle Schrauben mit dem in der Tabelle angegebenen Drehmoment festziehen.
- Die Elektroinstallation anschließen.

- Apretar los elementos A,D y E en el chasis con tornillos M10x35 8.8 (puntos 1 y 4).
- Apretar los elementos C a a barra de la grapa A y los elementos D y E con los tornillos M 12x35 (puntos 2, 3).
- Apretar la barra del gancho A com tornillos M12x40 (punto 1, 2).
- Apretar todos los tornillos con el par según la tabla anterior.
- Apretar la bola del gancho con tornillos M16x45.
- Conectar la instalación eléctrica.

