



TOYOTA

Hilux Revo

2015 -

Cat. No. T/103

E20

55R01/07*005882*00

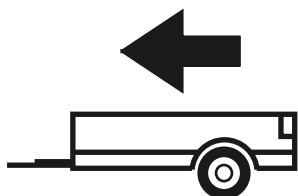

3 535kg

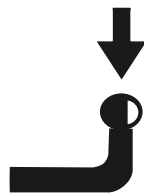

140kg

D = 16,50kN

D (kN) =



MAX kg

x

MAX kg

x 0,00981



MAX kg

+

MAX kg



IMIOLA HAK-POL

96-111 KOWIESY, CHOJNATA 23A, POLAND

tel. +48 46 831 73 31, fax +48 831 74 29

e-mail: office@imiola.pl, www.imiola.pl

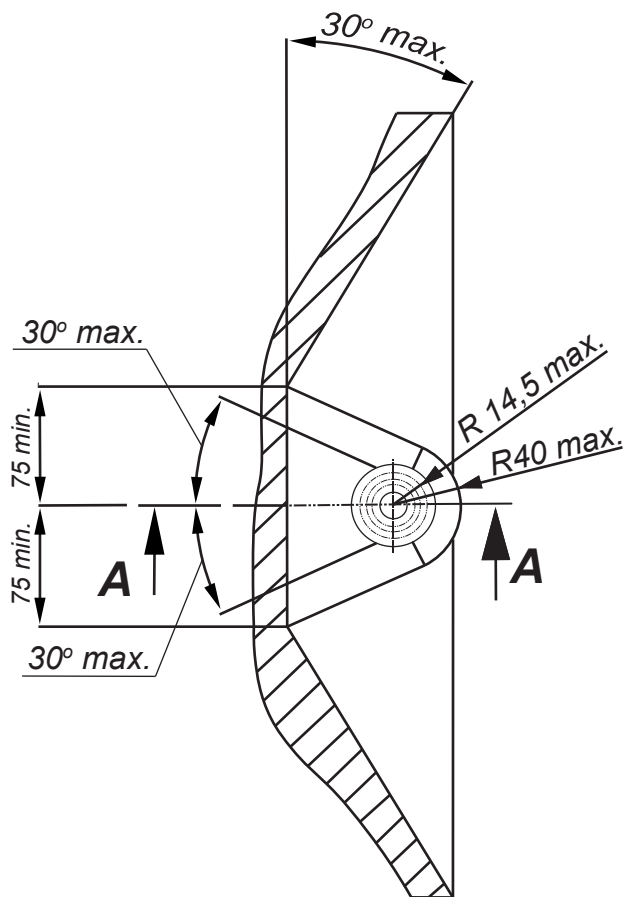

PRZEKRÓJ A-A

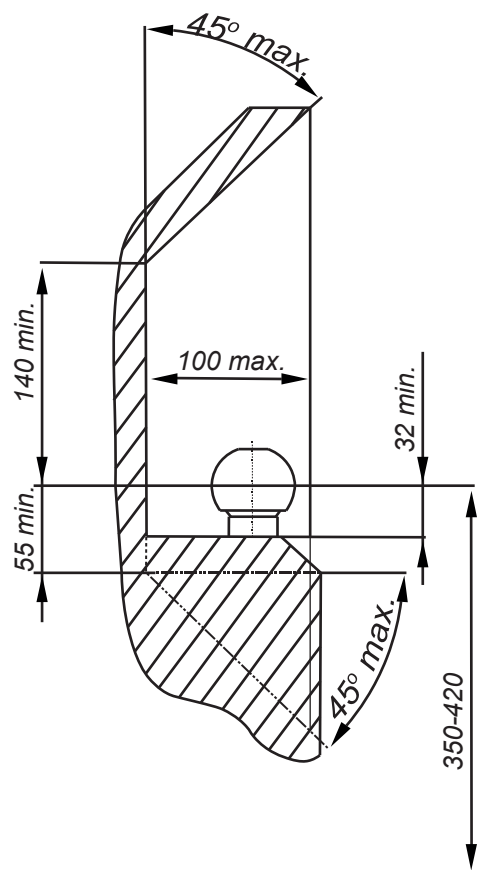

PL Należy zagwarantować przestrzeń swobodną według załącznika VII, rysunek 25a/b Regulaminu EKG ONZ 55.01 przy dopuszczalnym ciężarze całkowitym pojazdu.

F L'espace libre doit être garanti conformément à l'annexe VII, illustration de la réglementation 55.01 CE pour un poids total en charge autorisé du véhicule.

GB The clearance specified in appendix VII, diagram 25a/b of Regulation No. 55.01 UN EU must be guaranteed at laden weight of the vehicle.

D Der Freiraum nach Anhang VII, Abbildung 25a/b der Vorschriften 55.01 EG ist zu gewährleisten bei zulässigem Gesamtgewicht des Fahrzeuges.

Moment skrecający dla śrub i nakrętek (8.8) Torque settings for nuts and bolts (8.8)

M8	25Nm
M10	55Nm
M12	85Nm
M14	135Nm
M16	195Nm



Nakrętka M12; Nut
 Podkł. spręż. 12,2; Spring Washer
 Podkł. okr. 13; Plain Washer

Śruba M12x1,25x35-8.8; Bolt
 Podkł. spręż. 12,2; Spring Washer
 Podkł. okr. 13; Plain Washer

Nakrętka M12; Nut
 Podkł. spręż. 12,2; Spring Washer
 Podkł. okr. 13; Plain Washer

Śruba M12x45-8.8; Bolt

Śruba M10x25-8.8; Bolt

Nakrętka M16; Nut
 Podkł. spręż. 16,3; Spring Washer
 Podkł. okr. 17; Plain Washer

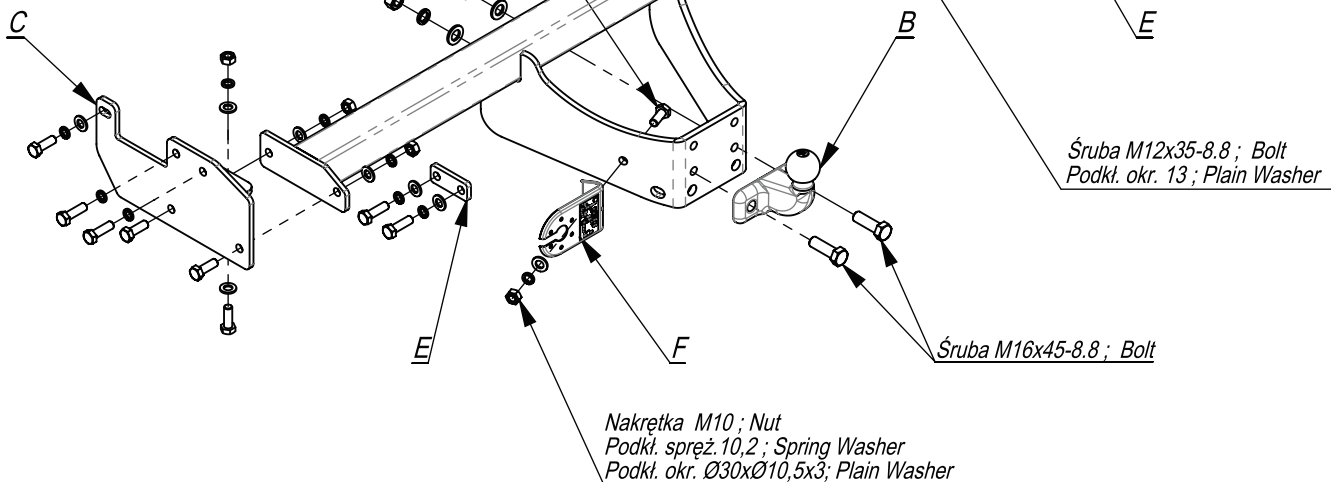

Śruba M12x35-8.8; Bolt
 Podkł. okr. 13; Plain Washer

Śruba M16x45-8.8; Bolt

Nakrętka M10; Nut
 Podkł. spręż. 10,2; Spring Washer
 Podkł. okr. Ø30xØ10,5x3; Plain Washer

	A	x1		M16x45	2
	B	x1		M12x45	4
	C	x1		M12x1,25x35	2
	D	x1		M12x35	2
	E	x2		M10x25	1
	F	x1		M16	2
				M12	6
				M10	1
				Ø30xØ10,5x3	1
				17	2
				13	10
				16,3	2
				12,2	8
				10,2	1

Nakrętka M12 ; Nut
Podkł. spręż. 12,2 ; Spring Washer
Podkł. okr. 13 ; Plain Washer

Śruba M12x1,25x35-8.8 ; Bolt
Podkł. spręż. 12,2 ; Spring Washer
Podkł. okr. 13 ; Plain Washer

Nakrętka M12 ; Nut
Podkł. spręż. 12,2 ; Spring Washer
Podkł. okr. 13 ; Plain Washer

Śruba M10x25-8.8 ; Bolt

Nakrętka M16 ; Nut
Podkł. spręż. 16,3 ; Spring Washer
Podkł. okr. 17 ; Plain Washer

Pkt. 2

Pkt. 3

Pkt. 4

Pkt. 1

C

Pkt. 2

Pkt. 3

Pkt. 4

Pkt. 1

Pkt. 2

Pkt. 3

Pkt. 4

Pkt. 1

Pkt. 2

Pkt. 3

Pkt. 4

E

Śruba M12x35-8.8 ; Bolt
Podkł. okr. 13 ; Plain Washer

Śruba M16x45-8.8 ; Bolt

Nakrętka M10 ; Nut
Podkł. spręż. 10,2 ; Spring Washer
Podkł. okr. Ø30xØ10,5x3 ; Plain Washer

Pkt. 1

E

F

Nr katalogowy

T/103

Marka

Toyota Hilux Revo

od 2015 ->



96-111 Kowiesy, Chojnata 23 A
tel. +48 46 831 73 31

