

Ref: **KAN13B2**

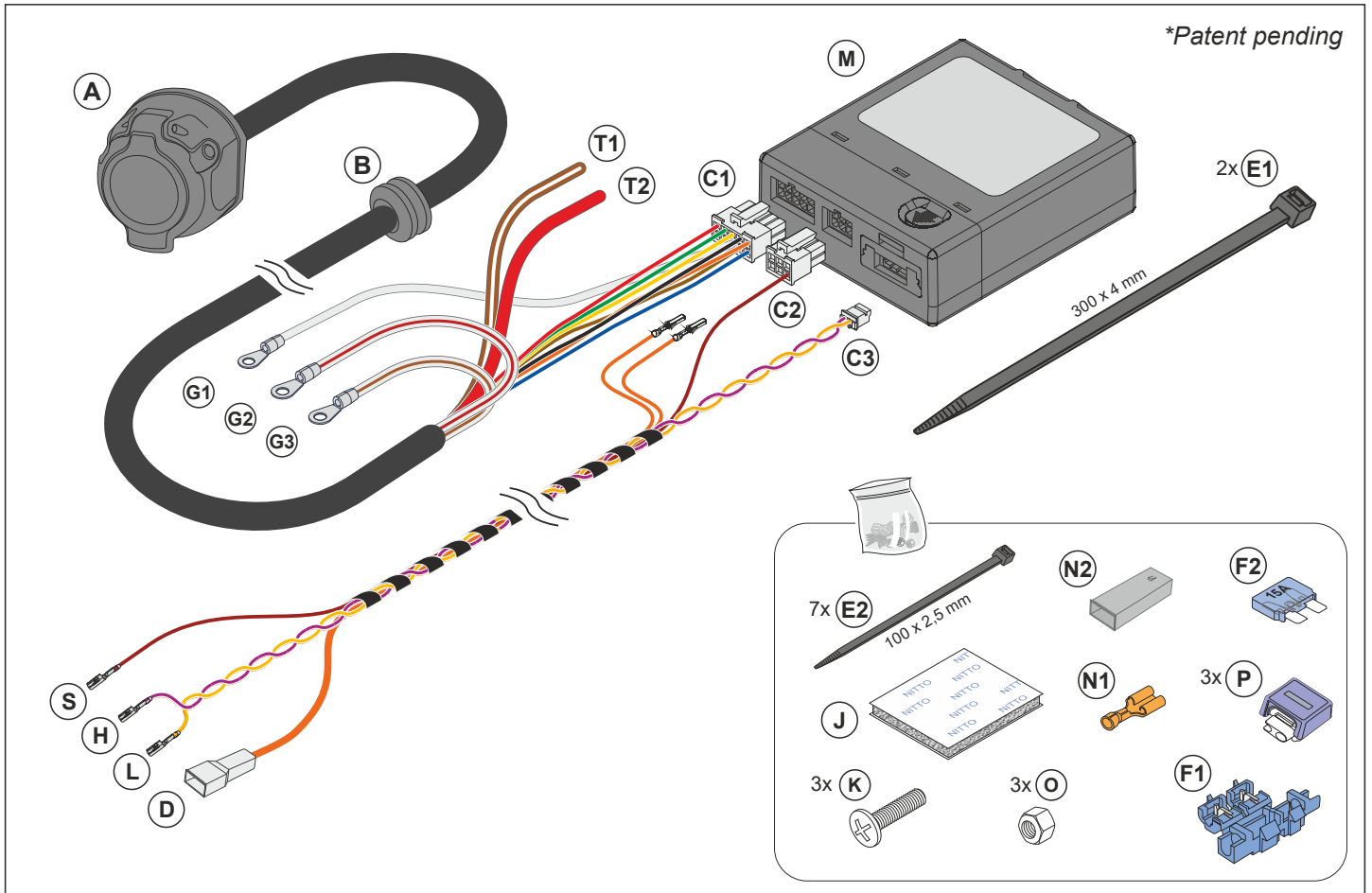

**Kit electrónico de remolque con contraseña de homologación Europea E9\*10R06/01\*5000\*00**  
Trailer wiring kit homologated according to EC Approval: E9\*10R06/01\*5000\*00

**ES** Instrucciones de montaje de kit electrónico de 13 polos de acuerdo a Norma DIN/ISO 11446. El montaje inapropiado o efectuado por personal no cualificado supone la pérdida de la garantía, de todo derecho a la indemnización y la expiración de toda responsabilidad civil respecto del producto.

**EN** Fitting instructions of towbar wiring kit with 13 pins socket according to DIN/ISO Norm 11446. The improper assembly or the fitting done by an unskilled person will automatically result in cancellation of the guarantee, the loss of any right of indemnity and the expiration of all product liability.

**FR** Notice de montage du faisceau elektro-satz por attelage de remorque avec prise du 13 plots conforme à la Norme DIN/ISO 11446. Une mauvaise installation ou celle effectuée par personnel non qualifié signifie la perte de la garantie, tout droit à indemnisation et à l'expiration de toute responsabilité civile sur le produit.

**IT** Istruzioni per l'installazione del kit elettronico 13 poli a norma DIN/ISO 11446. L'assemblaggio inadeguato o eseguito da personale non qualificato significa la perdita della garanzia, qualsiasi diritto al risarcimento e alla scadenza di ogni responsabilità per il prodotto.

**DE** 13 Polige Montageanleitung für elektronische gemäss DIN / ISO 11446. Eine unsachgemässe Montage durch nicht qualifiziertes Personal bedeutet den Verlust der Garantie, des Anspruchs auf Entschädigung und den Ablauf jeglicher zivilrechtlicher Haftung in Bezug auf die Produkt.

**PT** Instruções de instalação de kit eletrônico 13 pólos de acordo com DIN/ISO 11446. O montagem inadequada ou executados por pessoal não qualificado significa a perda da garantia, qualquer direito de indemnização e do termo de qualquer responsabilidade para o produto.

0

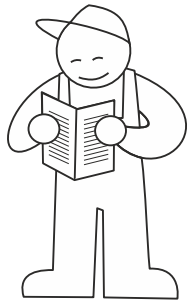

5 min.

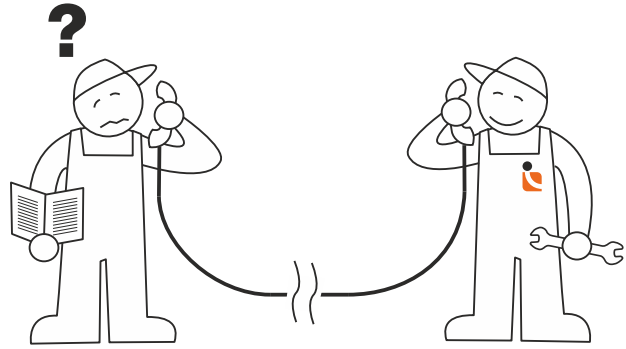

Tel.: (+34) 976 457 130

Conexión de la base de enchufe de 13 polos / 13 pins socket connection

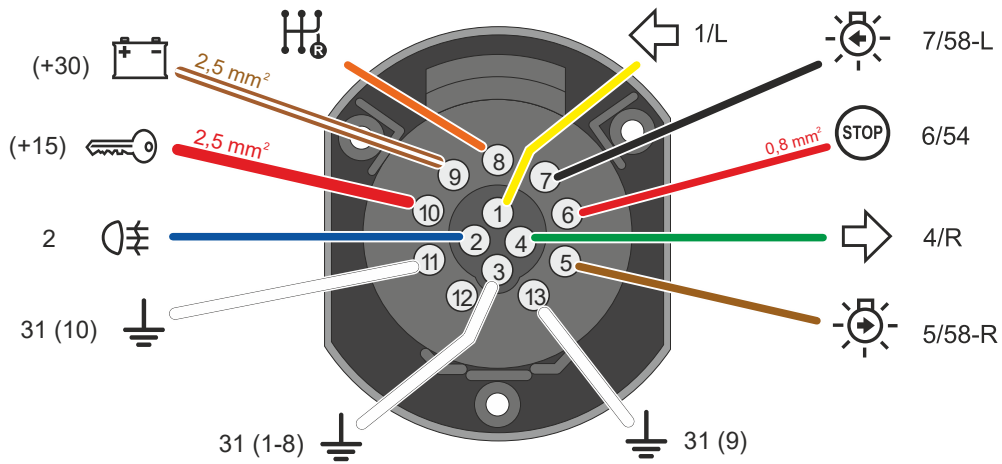

DIN / ISO 11446	ES	GB	FR	IT	DE	PT
1 ↵ 1/L	Intermitente izquierdo	Left indicator	Clignotant gauche	Freccia sinistra	Fahrtrichungs-anzeiger links	Vira à esquerda
2 ☹ 2	antiniebla trasera	rear fog light	Anti-brouillard	Retro-nebbia	Nebelschlussleuchte	Nevoeiro traseira
3 ⏚ 31 (1-8)	Masa (1-8)	Earth (1-8)	Masse (1-8)	Massa (1-8)	Masse (1-8)	Terra (1-8)
4 ➡ 4/R	Intermitente derecho	Right indicator	Clignotant droit	Freccia destra	Fahrtrichungs-anzeiger rechts	Vira à direita
5 ☼ 5/58R	Posición derecha	Right tail light	Veilleuse droite	Posizione destra	Rechte Schlussleuchte	Luz traseira direita
6 Ⓢ 6/54	Luz de freno	Brake light	Feu de stop	Luce d'arresto	Brem-sleuchte	Luz de freio
7 ☼ 7/58L	Posición izquierda	Left tail light	Veilleuse gauche	Posizione sinistra	Linke Schlussleuchte	Luz traseira esquerda
8 ⏚ 8	Marcha atrás	Reverse light	Marche arrière	Retro-marcia	Rückfahr-leuchte	Luz Reversa
9 ⏚ +30	Corriente continua	Permanent current	Courant continue	Positivo permanente	Permanent-strom	Corrente constante
10 ⏚ +15	Corriente de contacto	Contact current	Courant de contact	Positivo sottochiave	Schalter-strom	Corrente em chave
11 ⏚ 31 (10)	Masa (10)	Earth (10)	Masse (10)	Massa (10)	Masse (10)	Terra (10)
12 ∅ --	Pin vacío	Empty pin	Broche vide	Pin vuoto	Leere Kammer	Pino vazio
13 ⏚ 31 (9)	Masa (9)	Earth (9)	Masse (9)	Massa (9)	Masse (9)	Terra (9)

Info

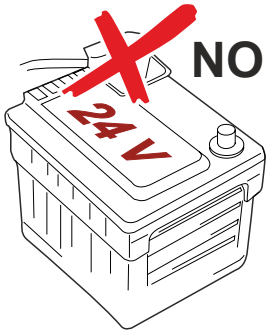

1

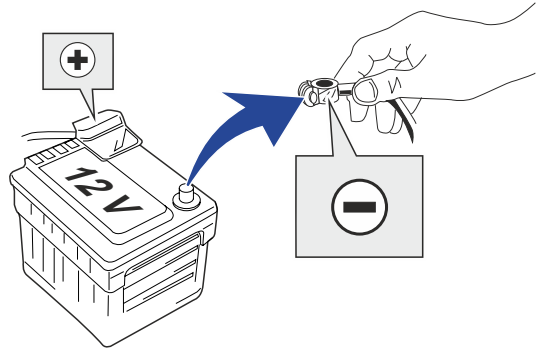

2

Cableado de salida de señales / Output signals wiring loom

1

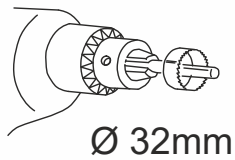

2

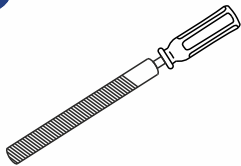

3

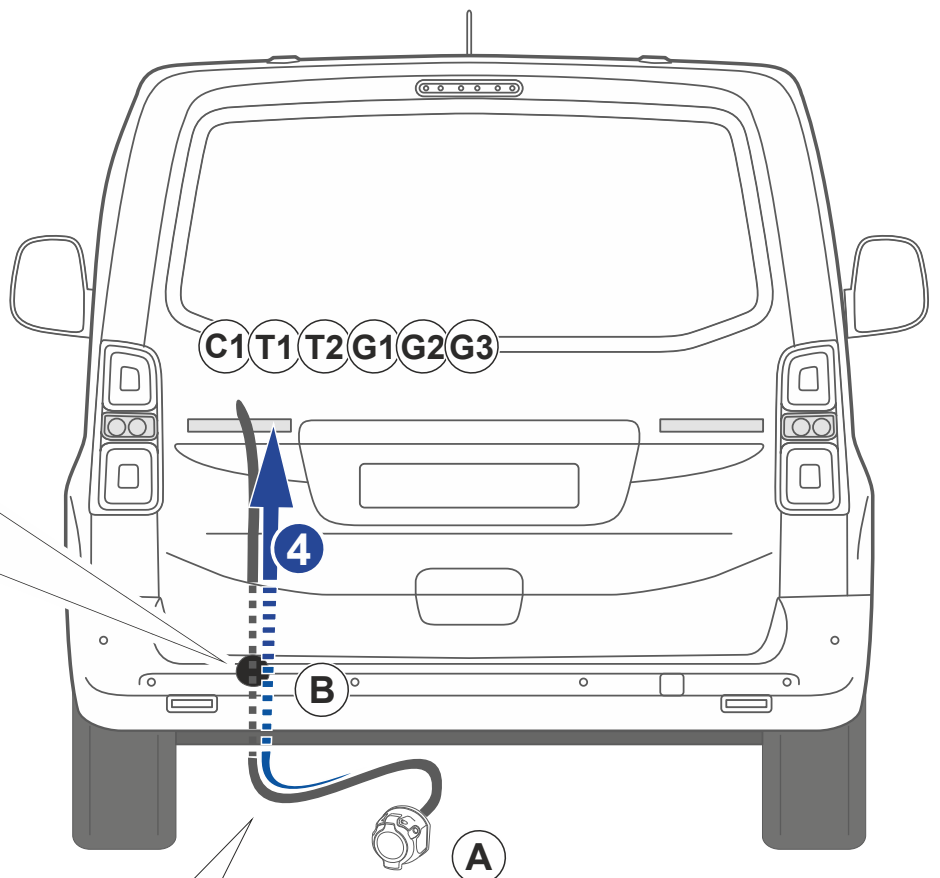
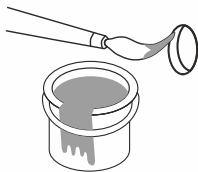

5

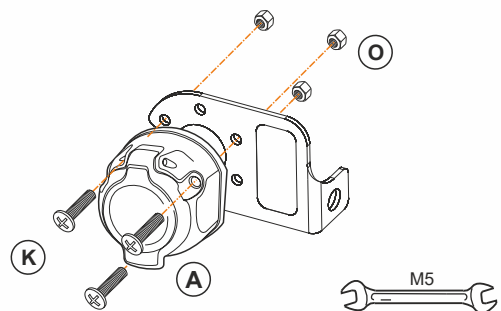

min 15 cm

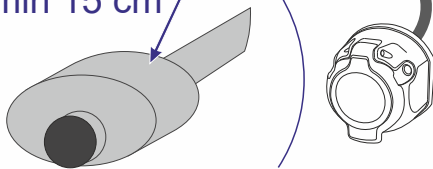

4 Conexiones de la centralita de remolque / Connections of the trailer module

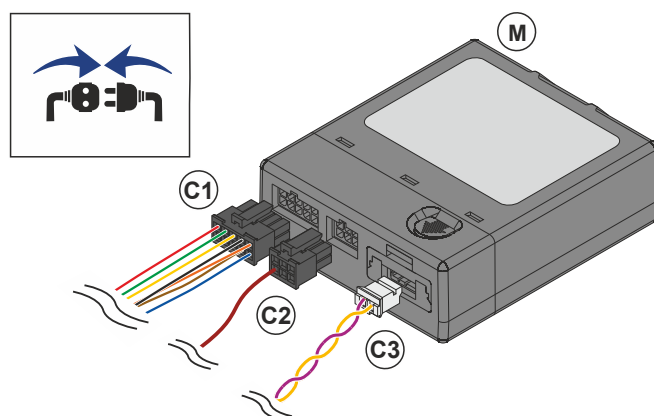
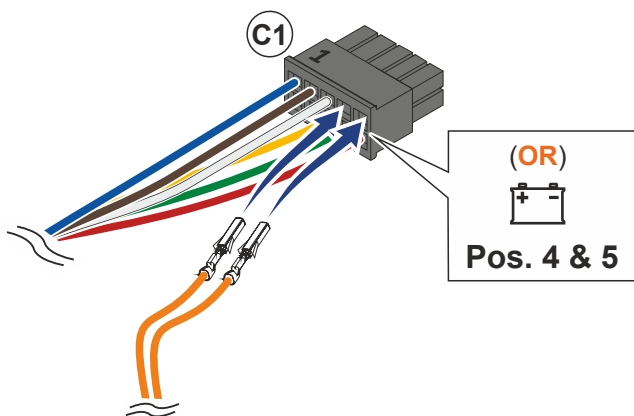

5 Fijación de la centralita / Fixation of the trailer module

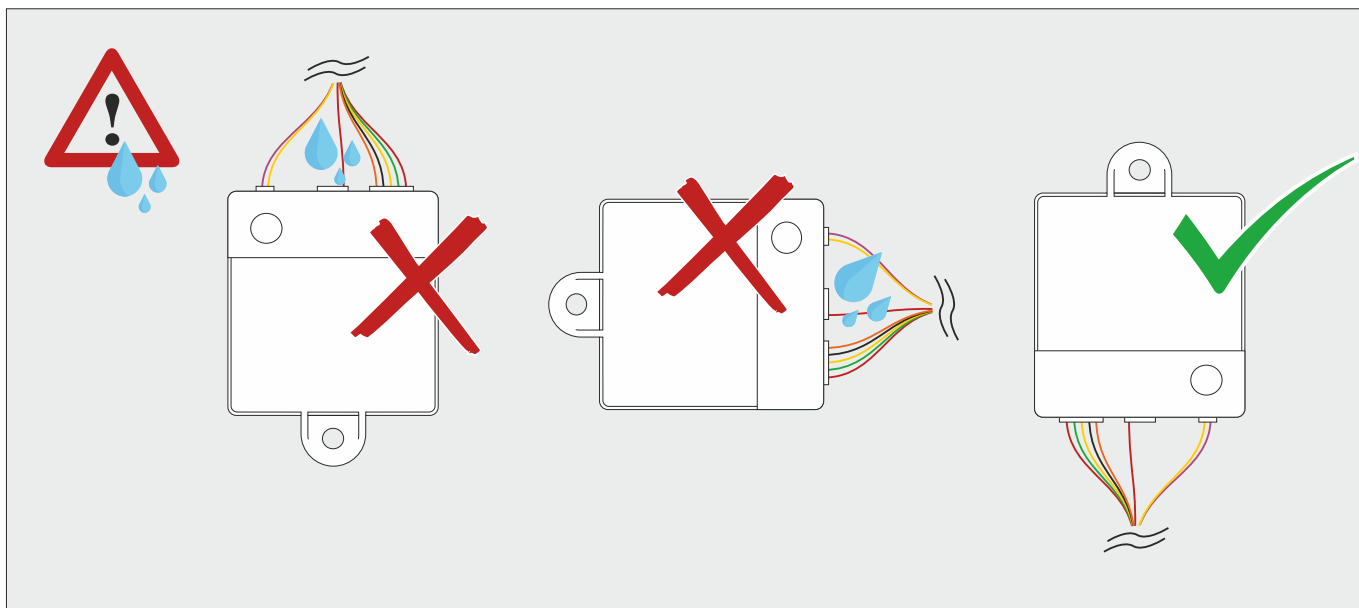
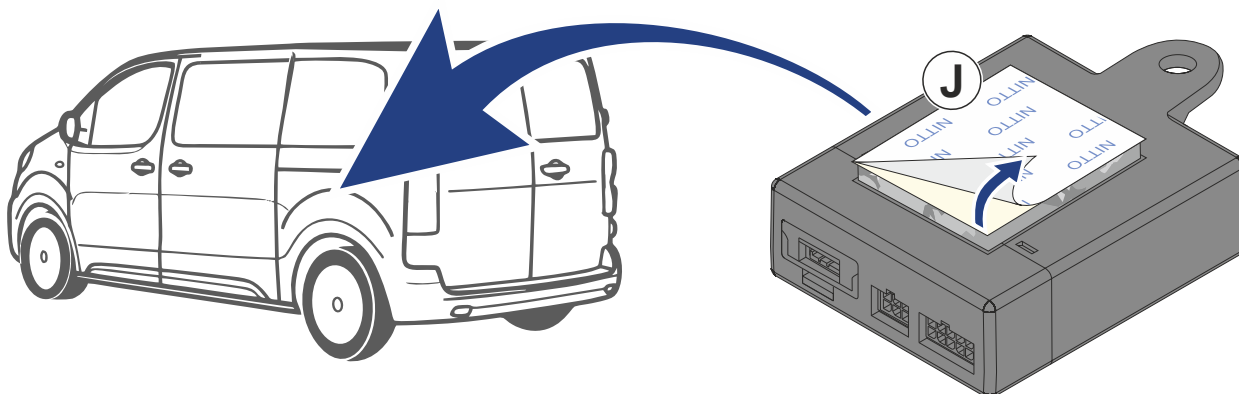

6 Guía del cableado / Harness routing

Opción 1: Furgón de carga / Option 1: LCVs

CAN H + CAN L + STOP + 



8

9

Opción 2: Pasajeros / Option 2: Passengers

CAN H + CAN L + STOP + 



10

11

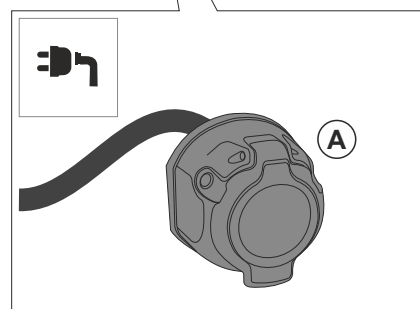
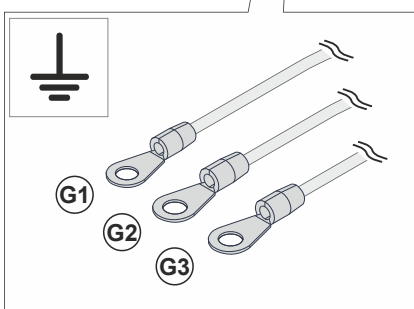
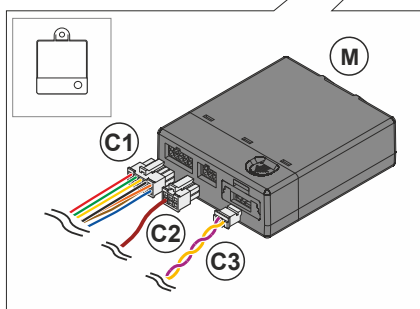
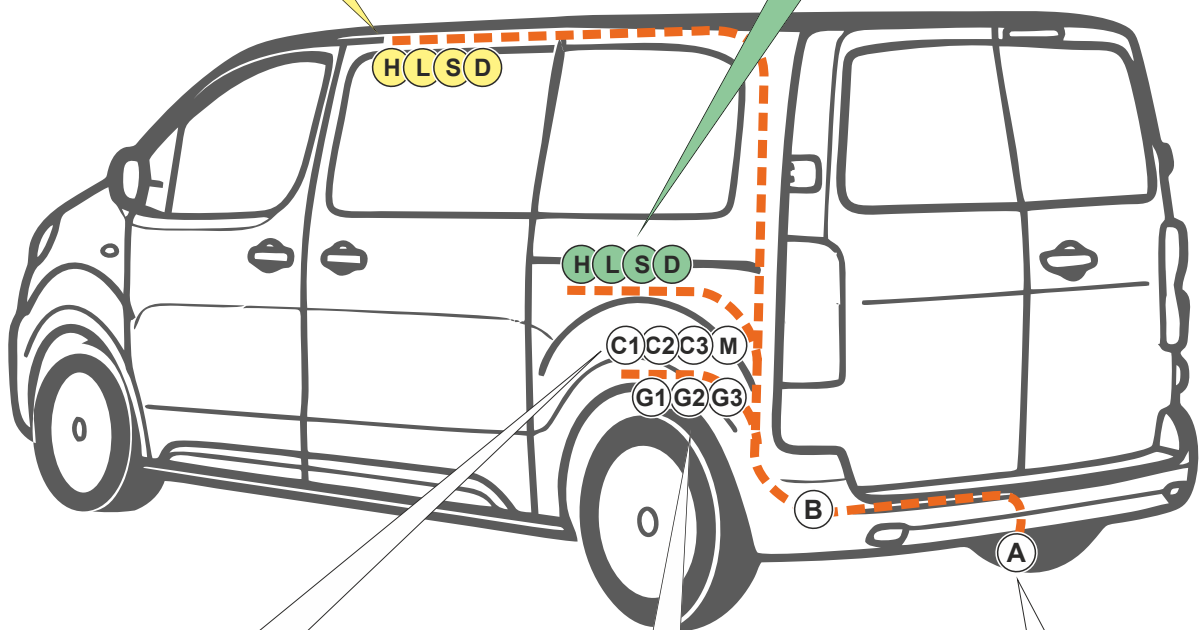

7 Conexión de la señal de freno / Connection of brake signal

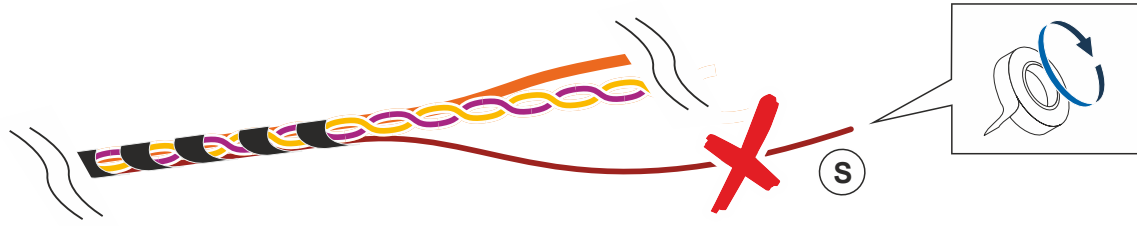

8 Conexión a la red CAN-Bus de furgonetas de carga / CAN-Bus connection for LCVs

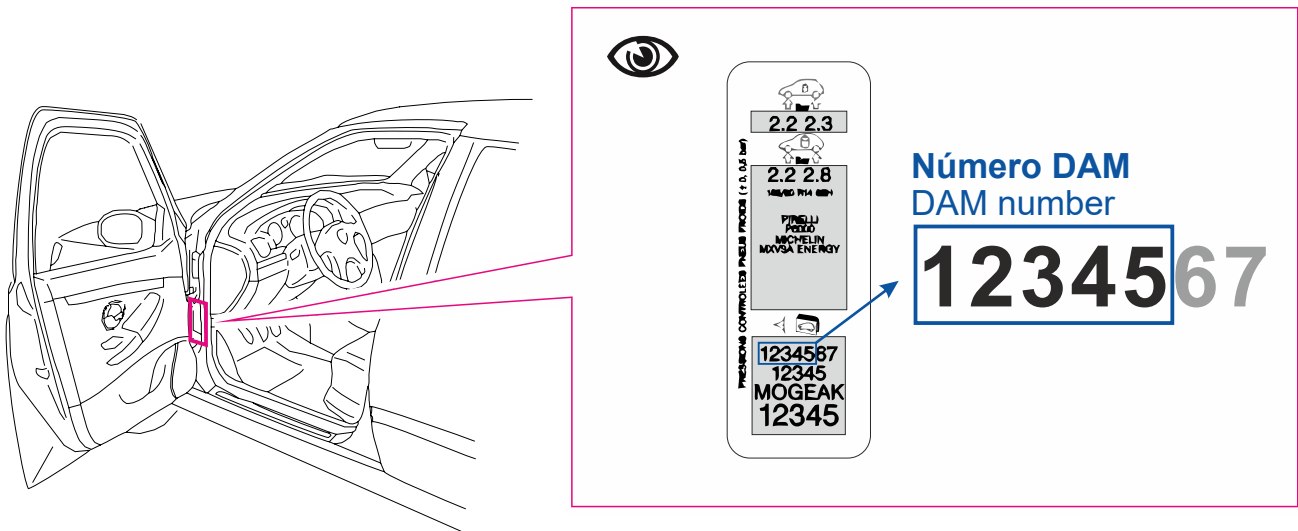

Opción 1 / Option 1:

**DAM < 15666** → Fecha de fabricación / Production date: (07/2016 - 09/2019)

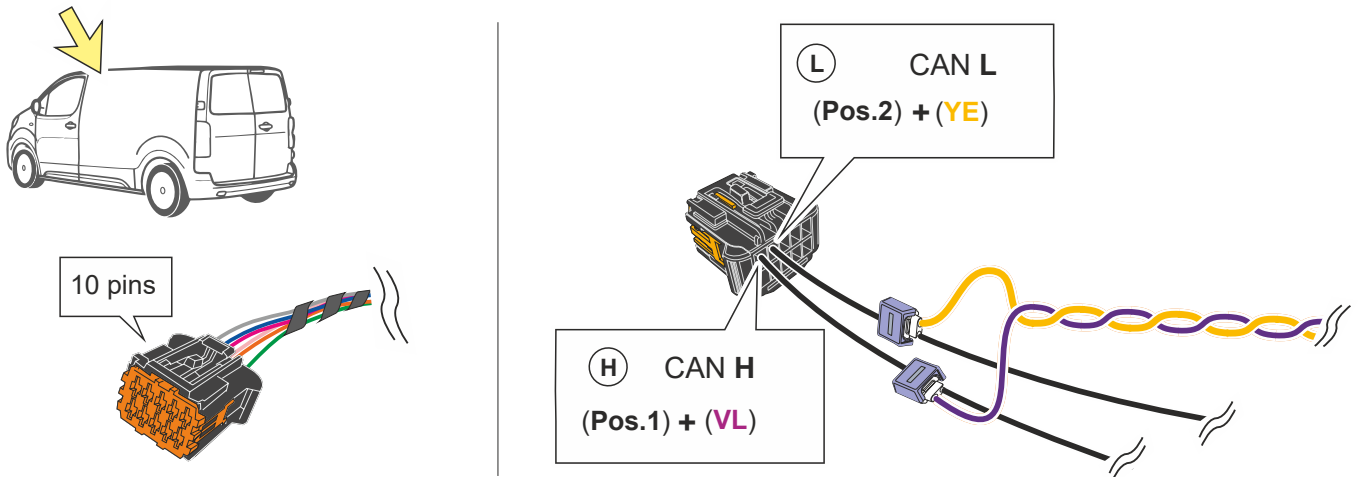

Opción 1 / Option 1:

**DAM ≥ 15667** → Fecha de fabricación / Production date: (10/2019 - )

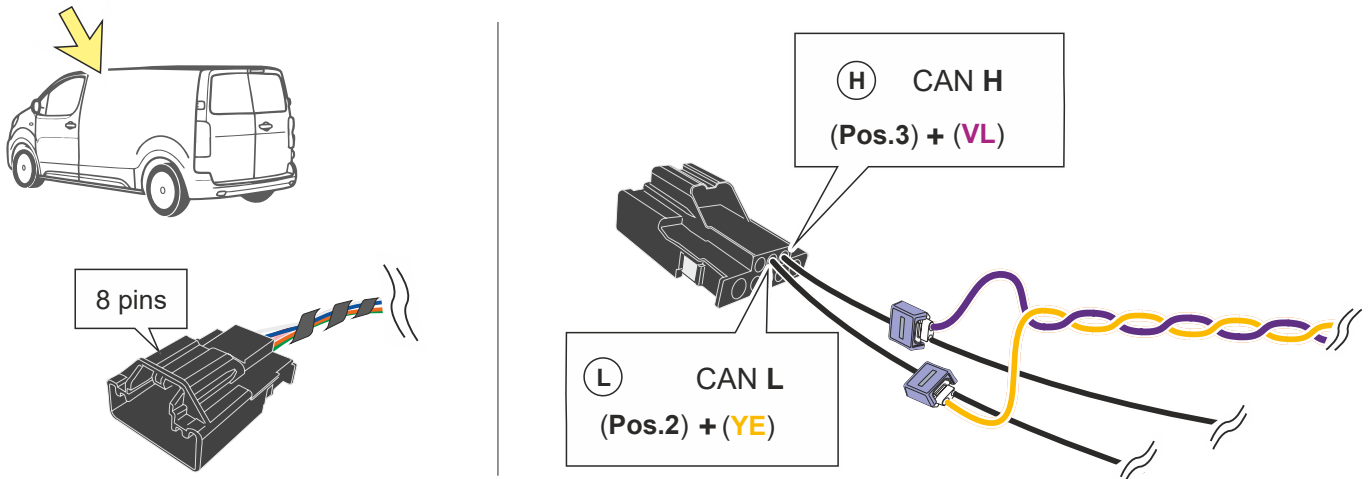

**9** Conexión de corriente (+30) en furgones de carga / Connection of constant current (+30) on LCVs

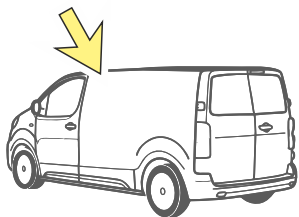

**Opción 1 / Option 1:**

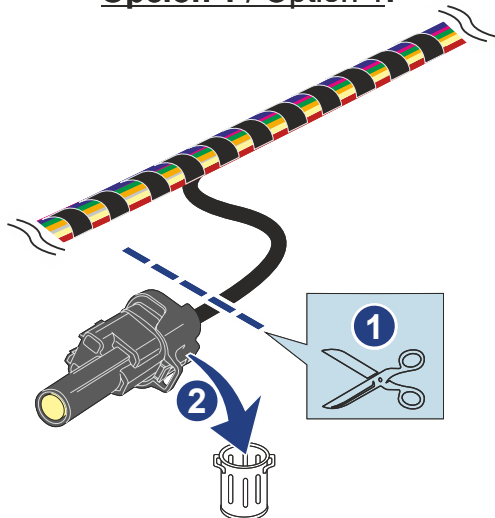

**Opción 2 / Option 2:**

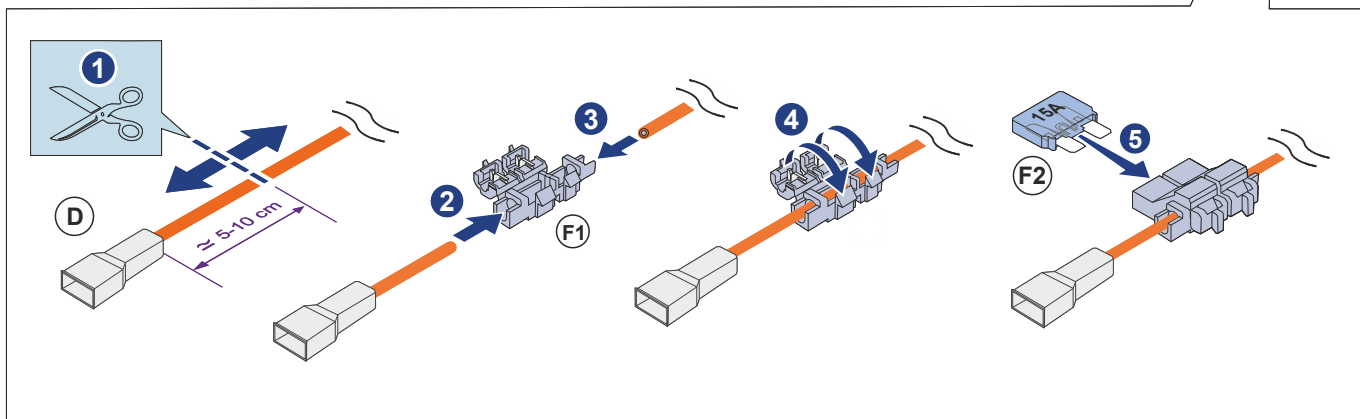
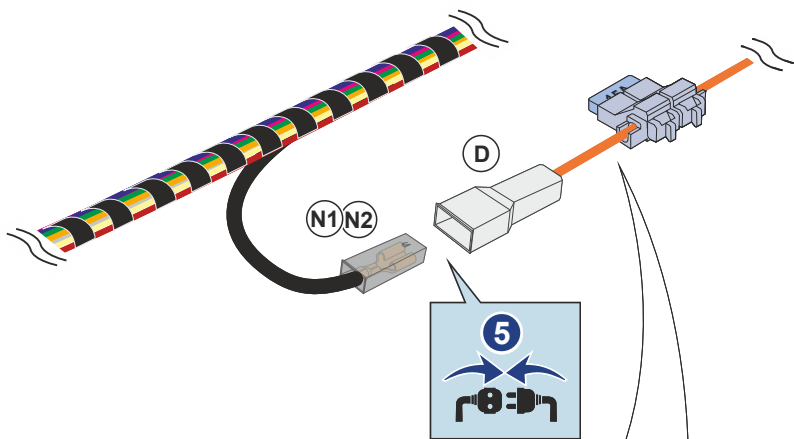
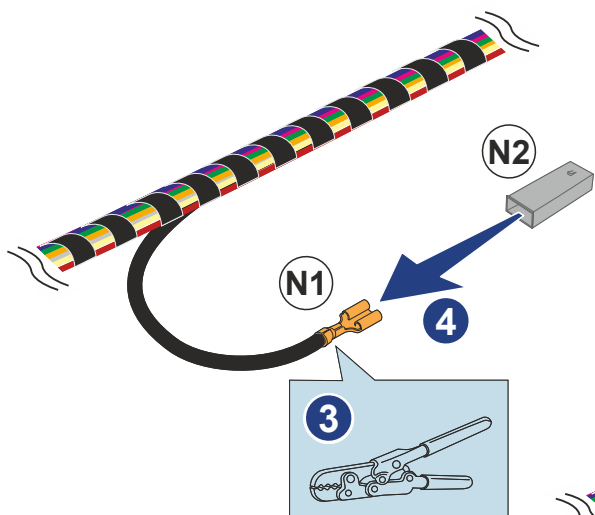
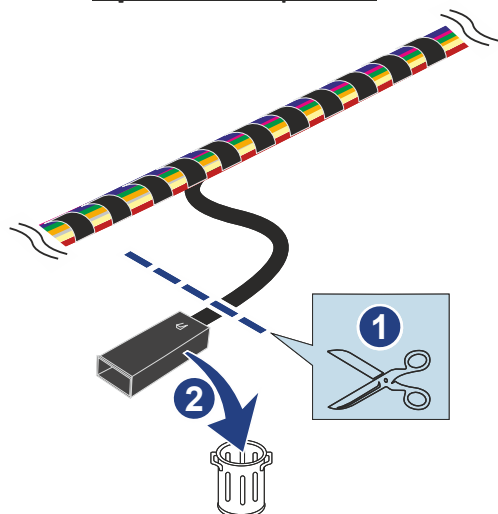

**10** Conexión a CAN-Bus en vehículos de pasajeros / CAN-Bus connection on passenger vans

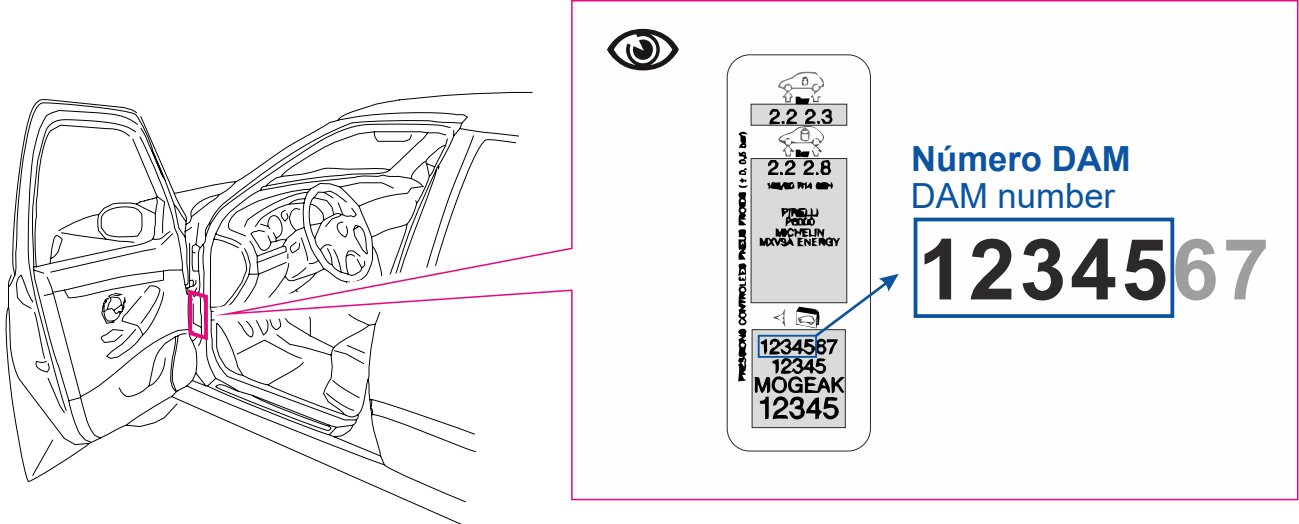

**Opción 1 / Option 1:**

**DAM < 15666** → Fecha de fabricación / Production date: (07/2016 - 09/2019)

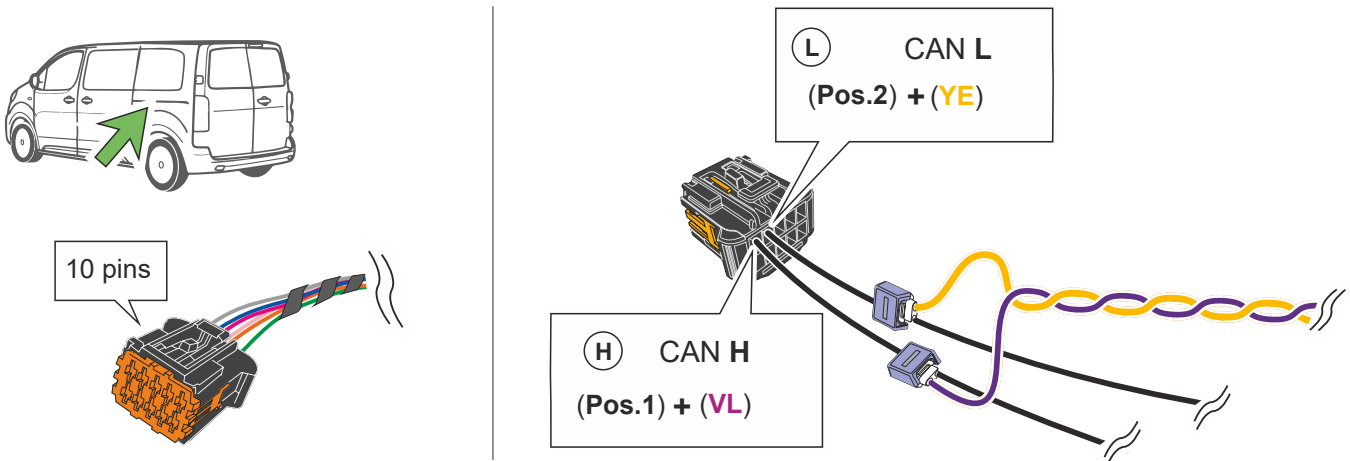

**Opción 2 / Option 2:**

**DAM ≥ 15667** → Fecha de fabricación / Production date: (10/2019 - )

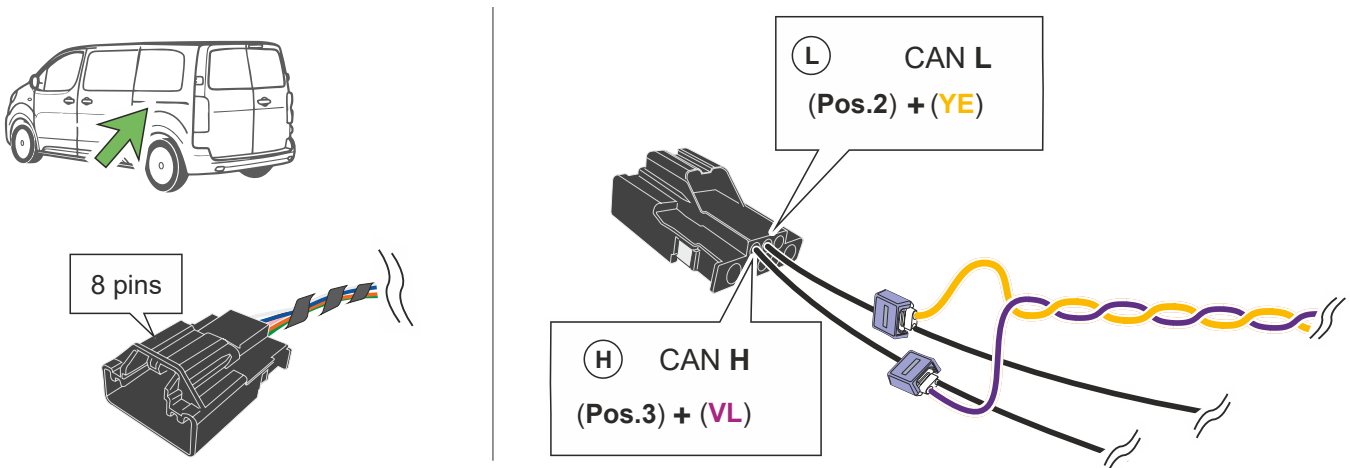



**11** Conexión de (+30) en vehículos de pasajeros / Connection of (+30) on passenger vehicles

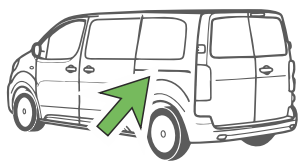

**Opción 1 / Option 1:**

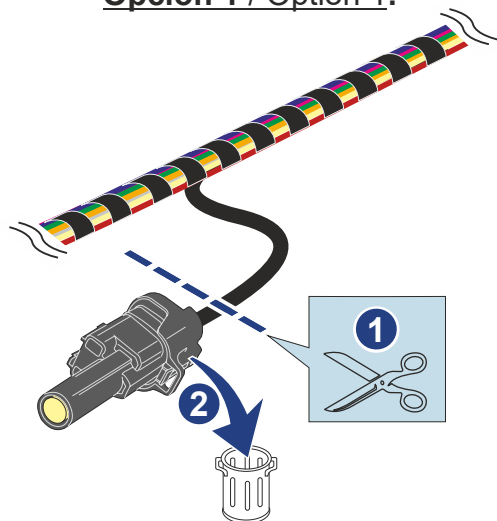

**Opción 2 / Option 2:**

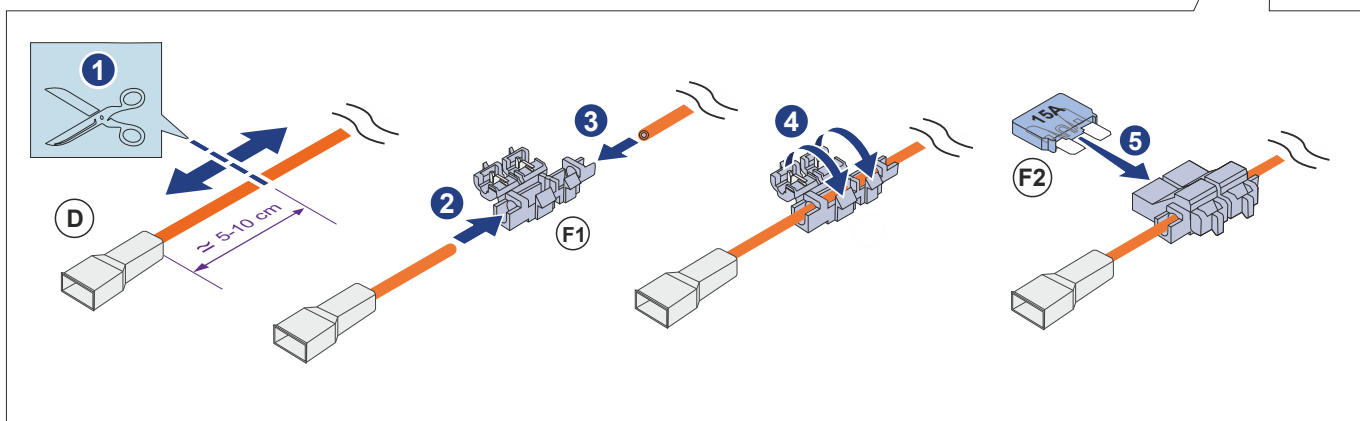
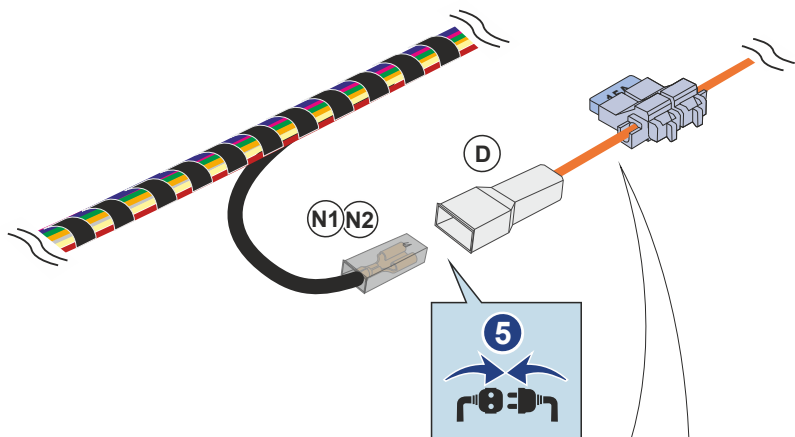
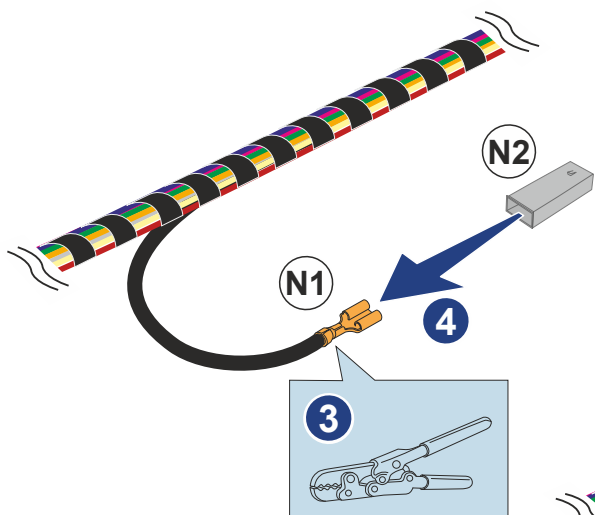
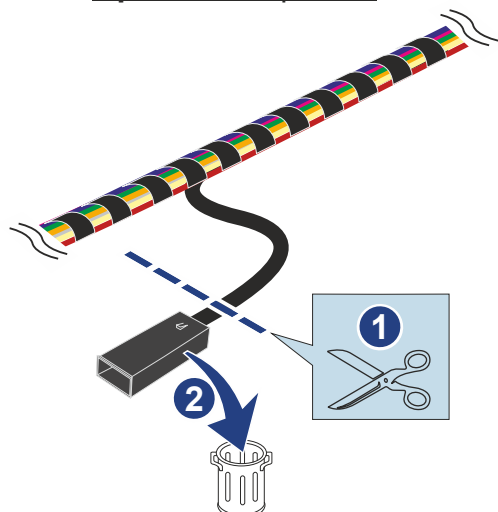

12 Conexión de masa / Earth cable connection

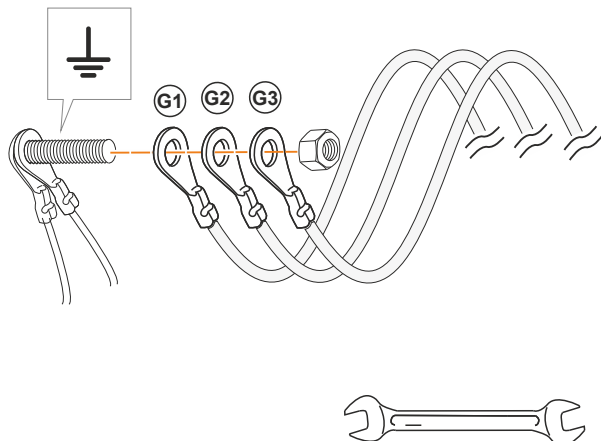

13 Borne negativo de la batería / Battery earth

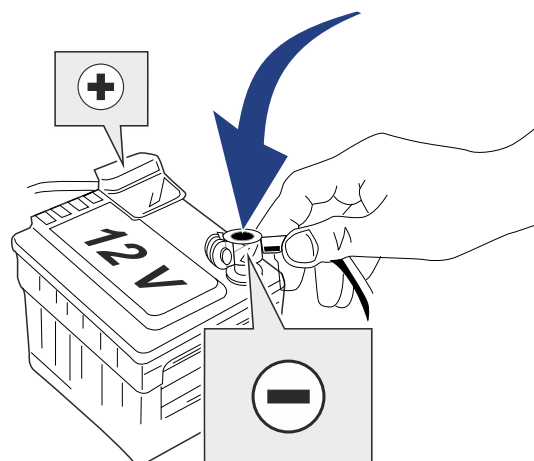

14 Activación de las funciones de remolque / Activation of trailer functions

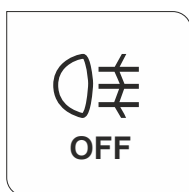
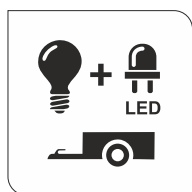
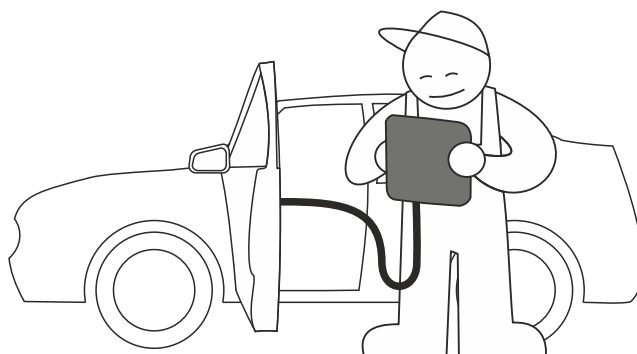

Máquina de diagnóstico AutoCodeEnganches



Ref. / Part Nr. **AUTOCODEENG2**

**15** Comprobación de alumbrado / Lightning check

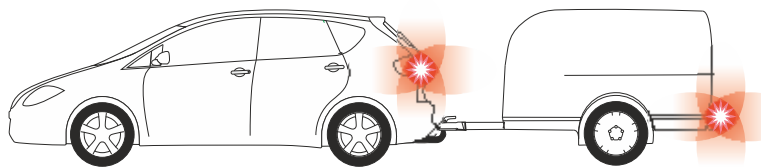

<input checked="" type="checkbox"/>	<input type="checkbox"/>	<input type="checkbox"/>	<input type="checkbox"/>	<input type="checkbox"/>	<input type="checkbox"/>	<input type="checkbox"/>

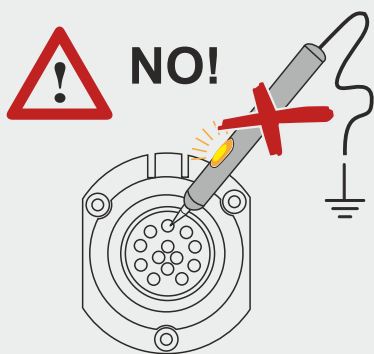

Comprobador Profesional ATT / ATT Professional Tester



Ref. / Part Nr. ALV0C51

**16** Accesorios opcionales: tomas de caravana / Optional accessories: caravan power supplies

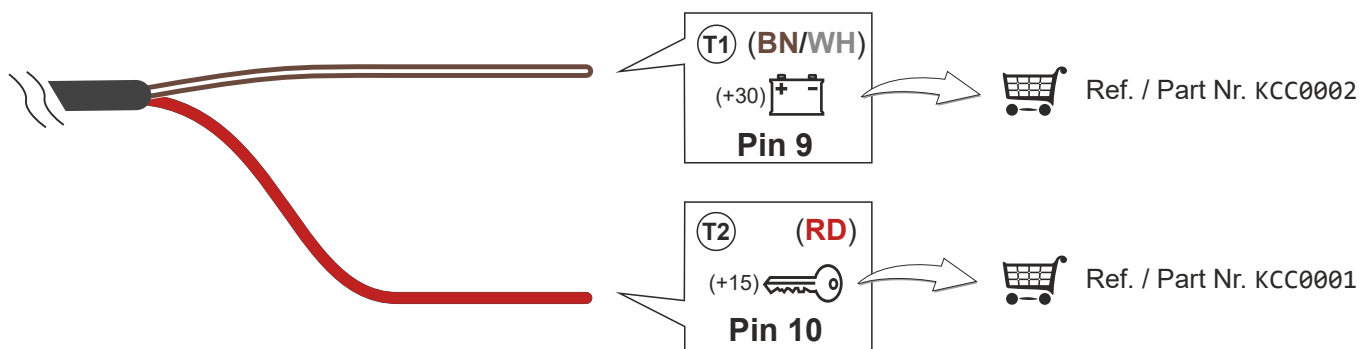

**Sigue nuestra actualidad en nuestras redes sociales:**  
Follow our news on our social networks:

