

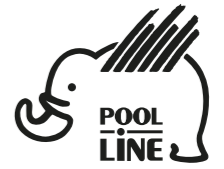

- E** Instrucciones de montaje
- C** Instruccions de muntatge
- GB** Assembly instructions
- F** Instruction de montage
- D** Montageanleitung
- PT** Instruções de montagem
- I** Istruzioni di montaggio
- PL** Instrukcja montażu
- CZ** Montážní návod
- HU** Szerelési Utasítás
- RO** Instrucțiuni de montaj
- HR** Detaljne upute
- TU** Öncelikle montaj











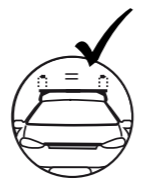
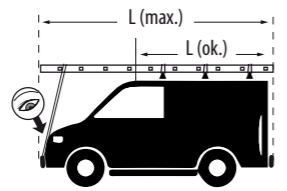
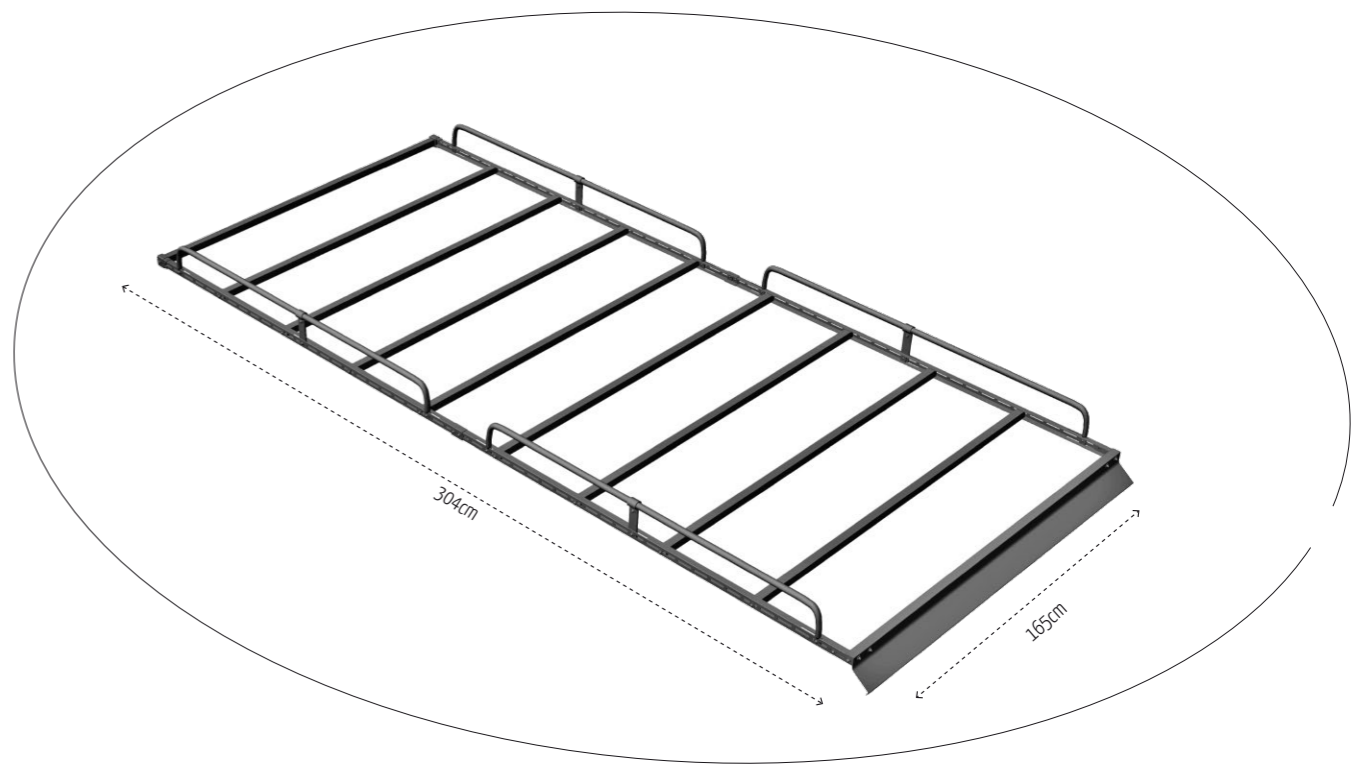

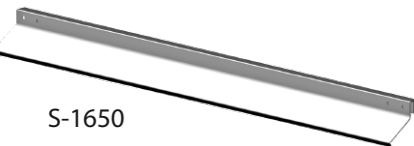





POOL-LINE ACCESORIOS, S.L.  
 C. Esqueis, 19. P. I. Can Barri  
 08415- Bigues i Riells. Barcelona (España)  
 www.pool-line.net

<span style="font-size: 2em; font-weight: bold; margin-left: 20px;">200</span> <span style="font-size: 1.5em; font-weight: bold; margin-left: 10px;">KG. MAX.</span>
Nº HOMOLOGACIÓN: <span style="border: 1px solid black; border-radius: 50%; padding: 2px 5px;">E9</span> 26R-03.1042
<div style="display: flex; justify-content: space-around; align-items: center;"> </div> <span style="font-size: 0.8em; font-weight: bold; margin-left: 100px;">RECICLABLE</span>

123616

Rv: 05/2024



N		Q
1	 S-1650	1
2	 L-1540	4
3	 B-1262	4
4	 T-1635	9
7		18
8		2
9		2
10		10
11		1
12	 CHA-M8	16
13	 ISO 7380 M8x30	18
14	 ISO 7380 M8x16	24
15	 DIN 125 Ø 8	42
16		8
17	 DIN 603 M6x12	4
18	 DIN 6923 M6	4

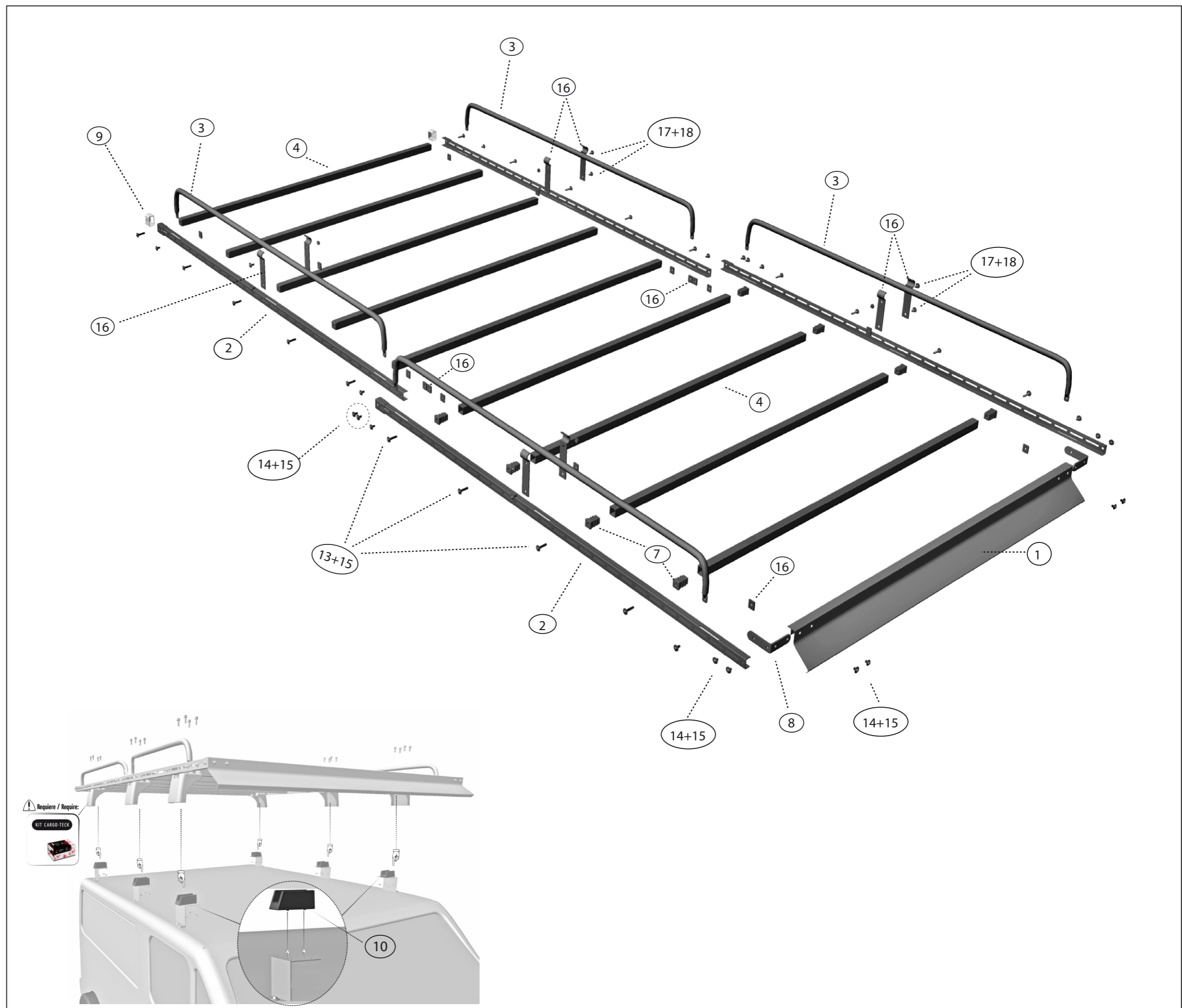



Zona delantera  
Zone avant  
Front zone  
Zone anteriore  
Vorderzone



Zona delantera  
Zone avant  
Front zone  
Zone anteriore  
Vorderzone

- CITROËN JUMPER L1 H1 (2006->)
- FIAT DUCATO L1 H1 (2006->)
- OPEL MOVANO C L1 H1 (2021->)
- PEUGEOT BOXER L1 H1 (2006->)

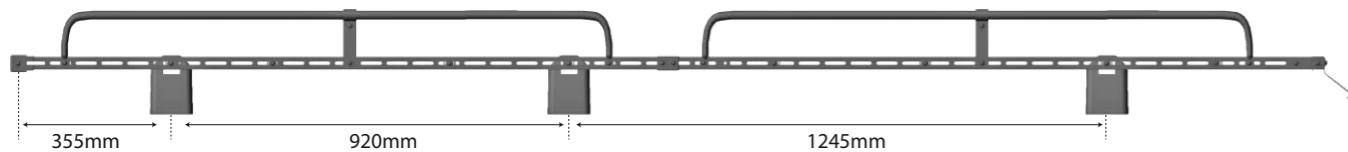

- LDV MAXUS L2-H2 (2008->)
- RENAUL TRAFIC I L1-H1 (81-01)
- TOYOTA HIACE L1-H1 (04-19)

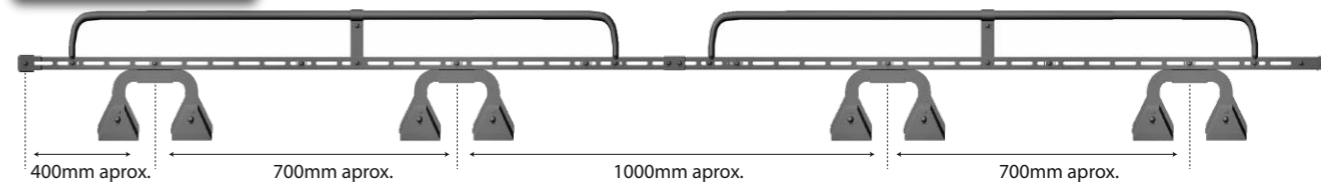

- CITROËN JUMPER L2 H1 (1994 - 2006)
- FIAT DUCATO L2 H1 (1994 - 2006)
- PEUGEOT BOXER L2 H1 (1994 - 2006)

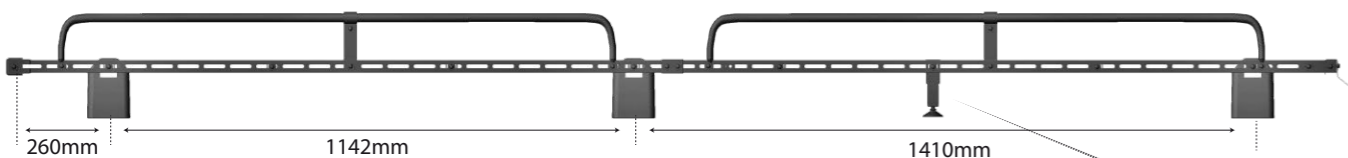

- CITROËN JUMPER L2 H2 (2006->)
- FIAT DUCATO L2 H2 (2006->)
- OPEL MOVANO C L2 H2 (2021->)
- PEUGEOT BOXER L2 H2 (2006->)

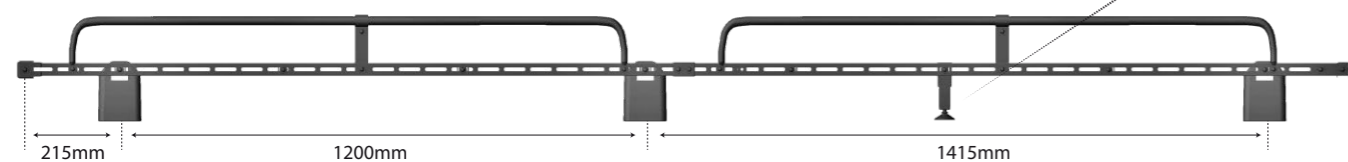

- IVECO DAILY VI (7,3m³) 3000 - H1 (2014->)

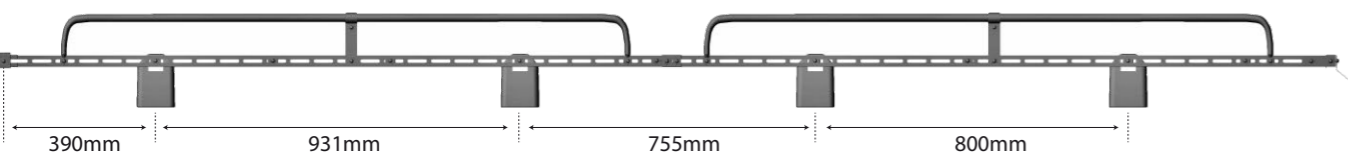

1

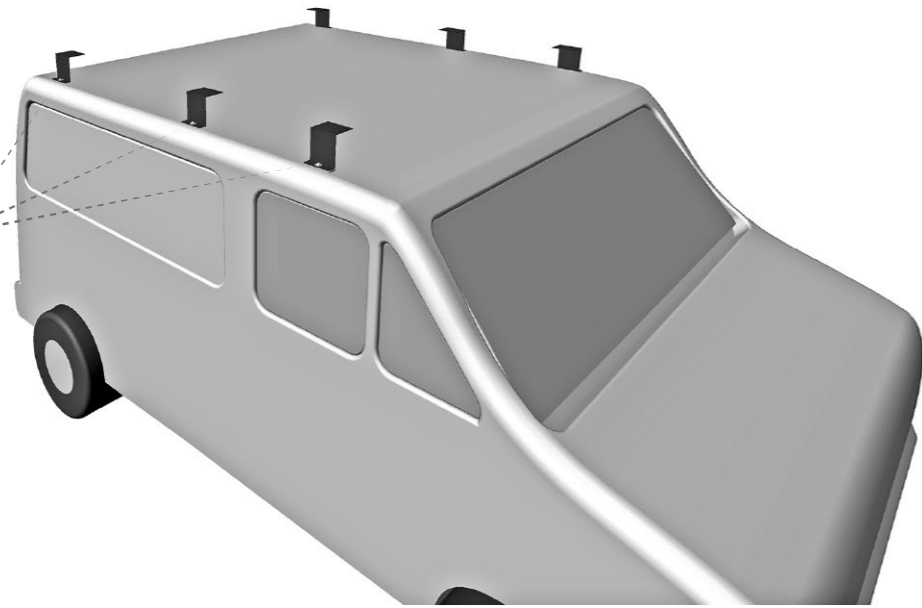

2

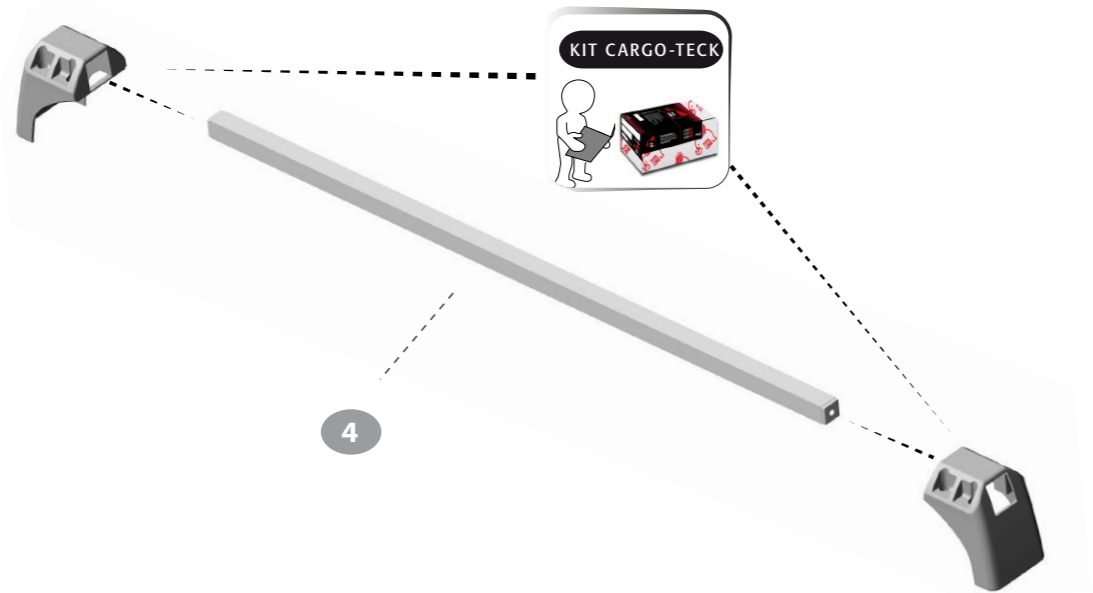

3

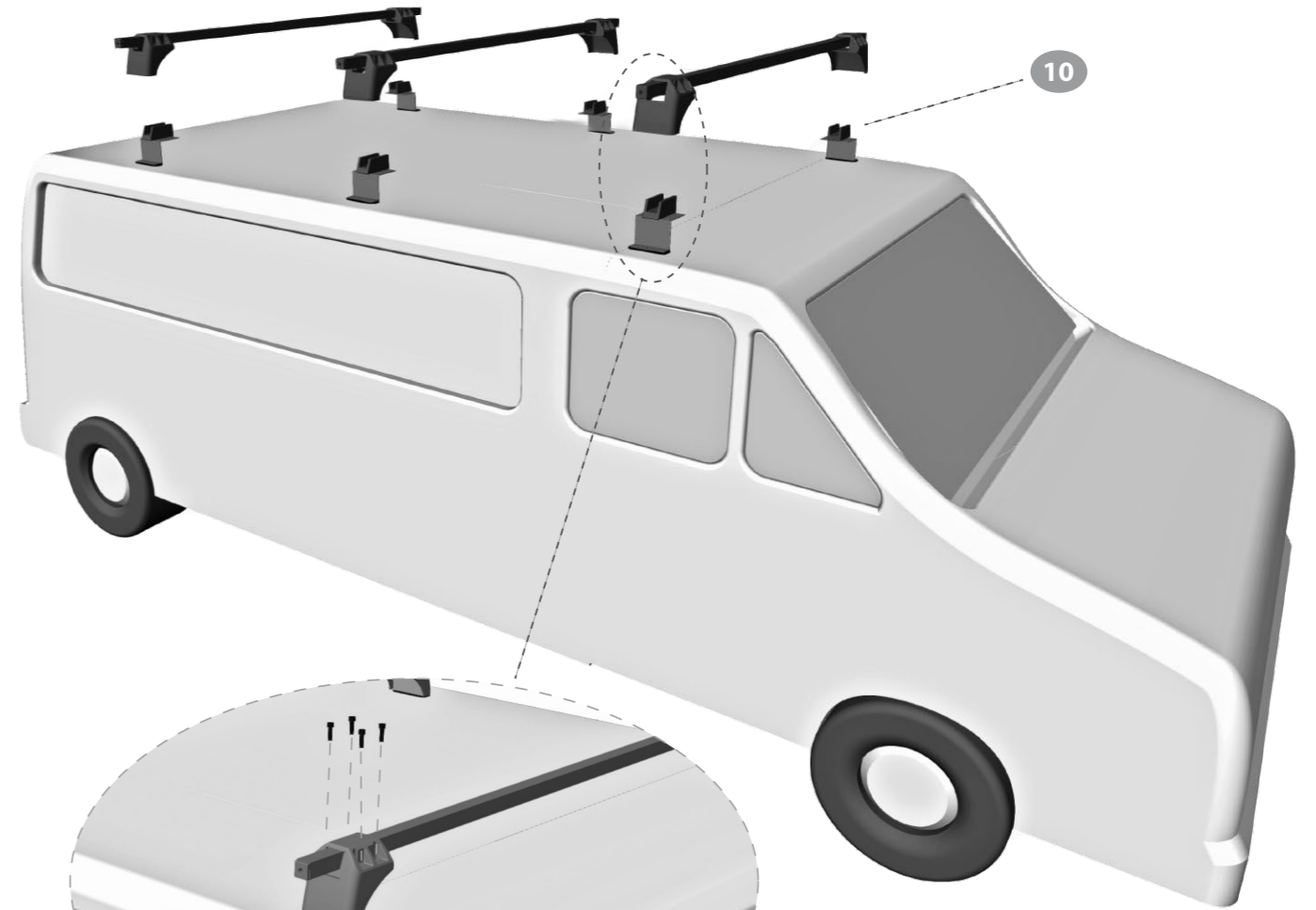



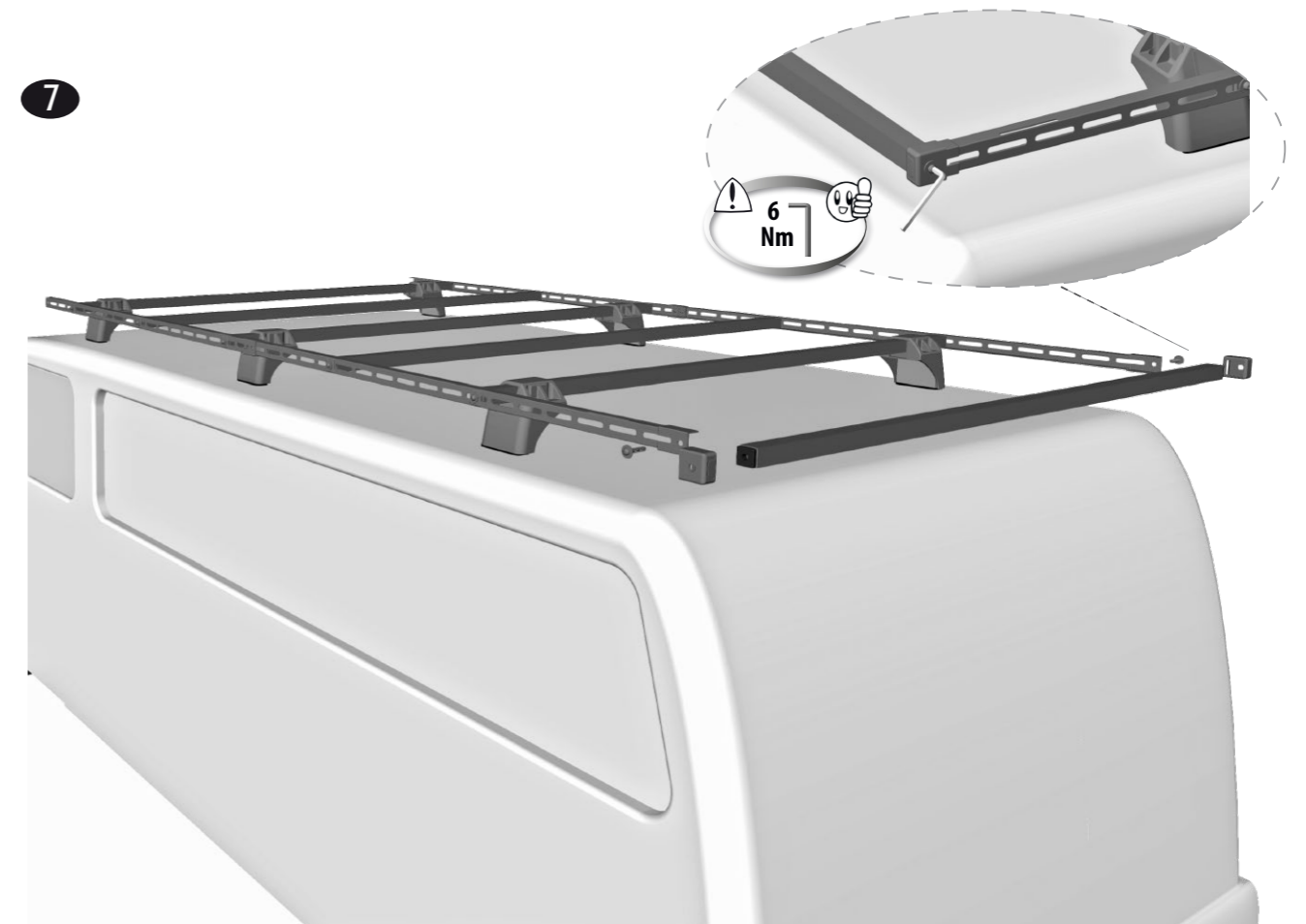
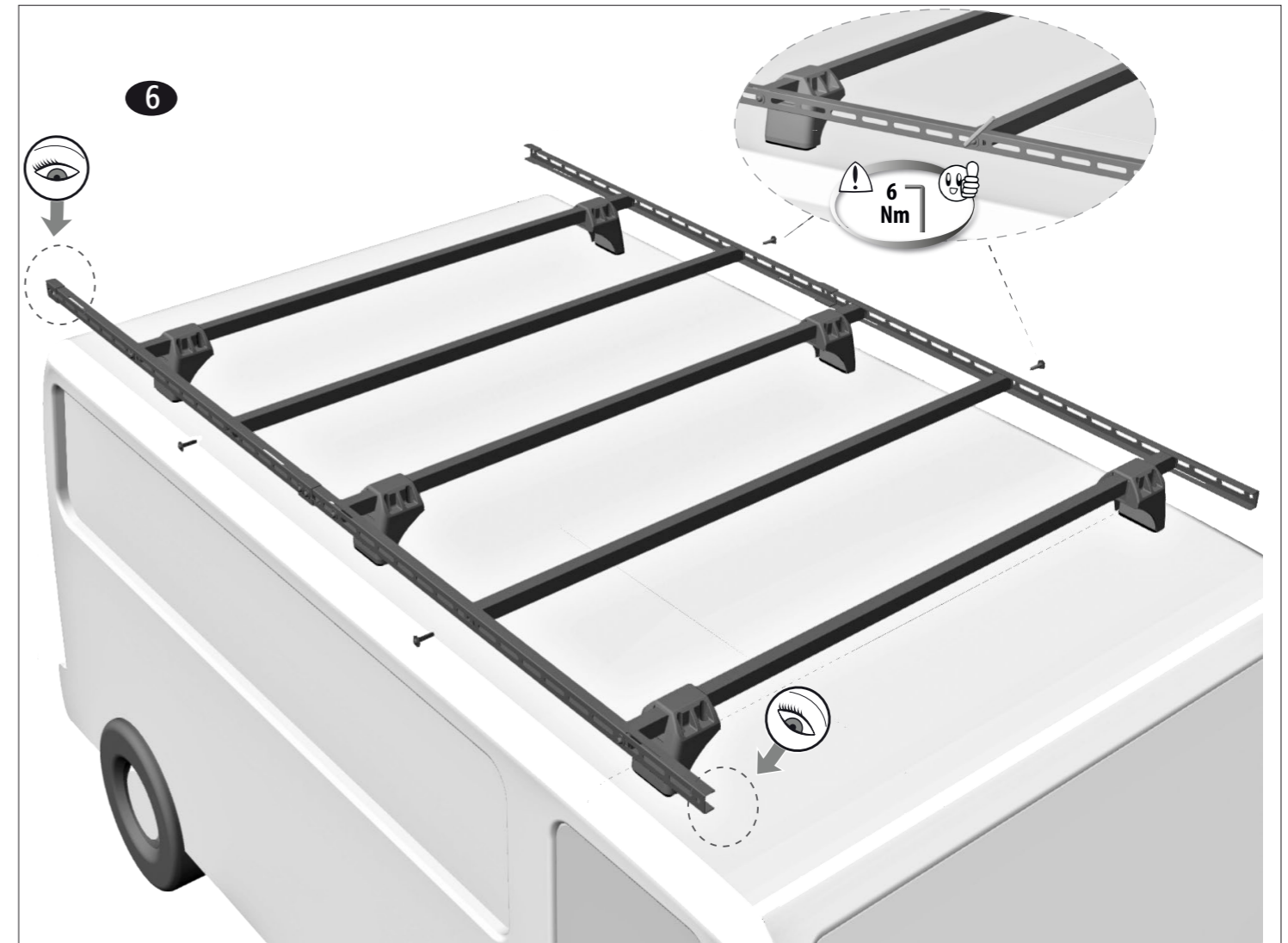
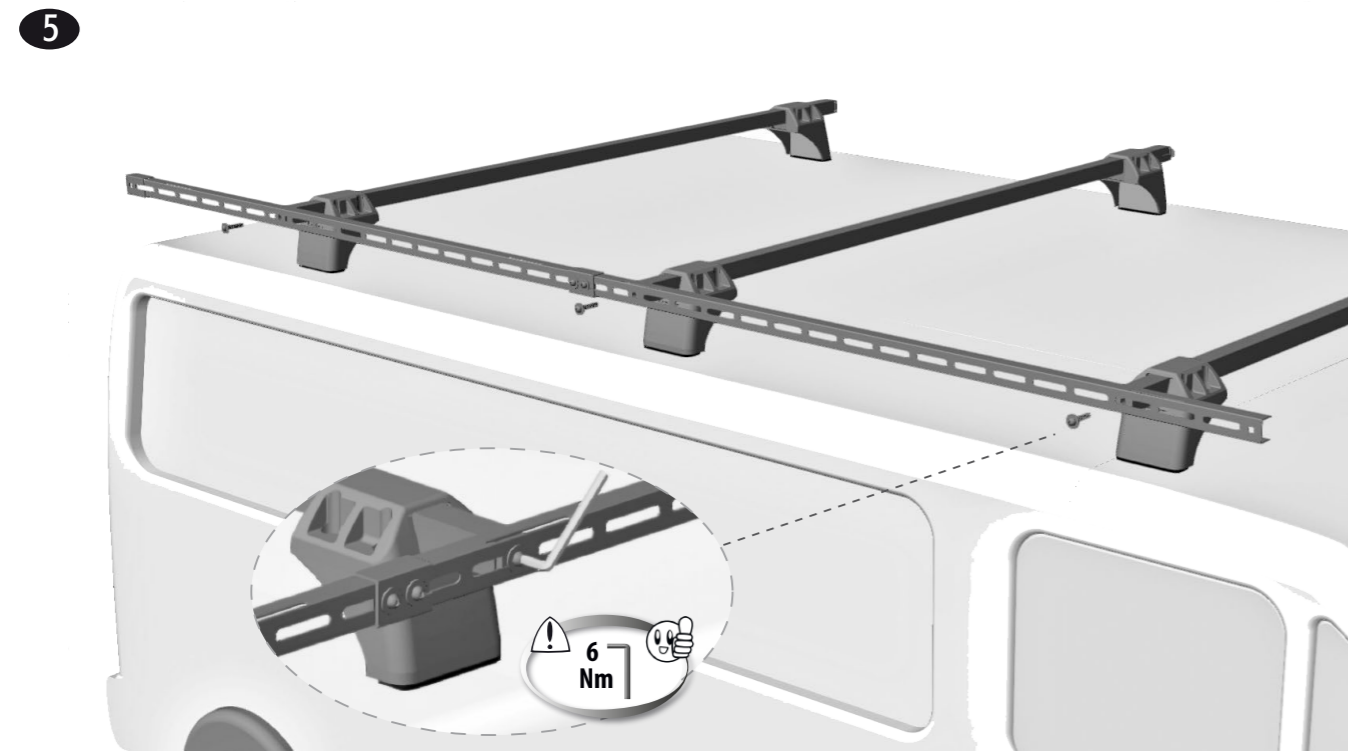
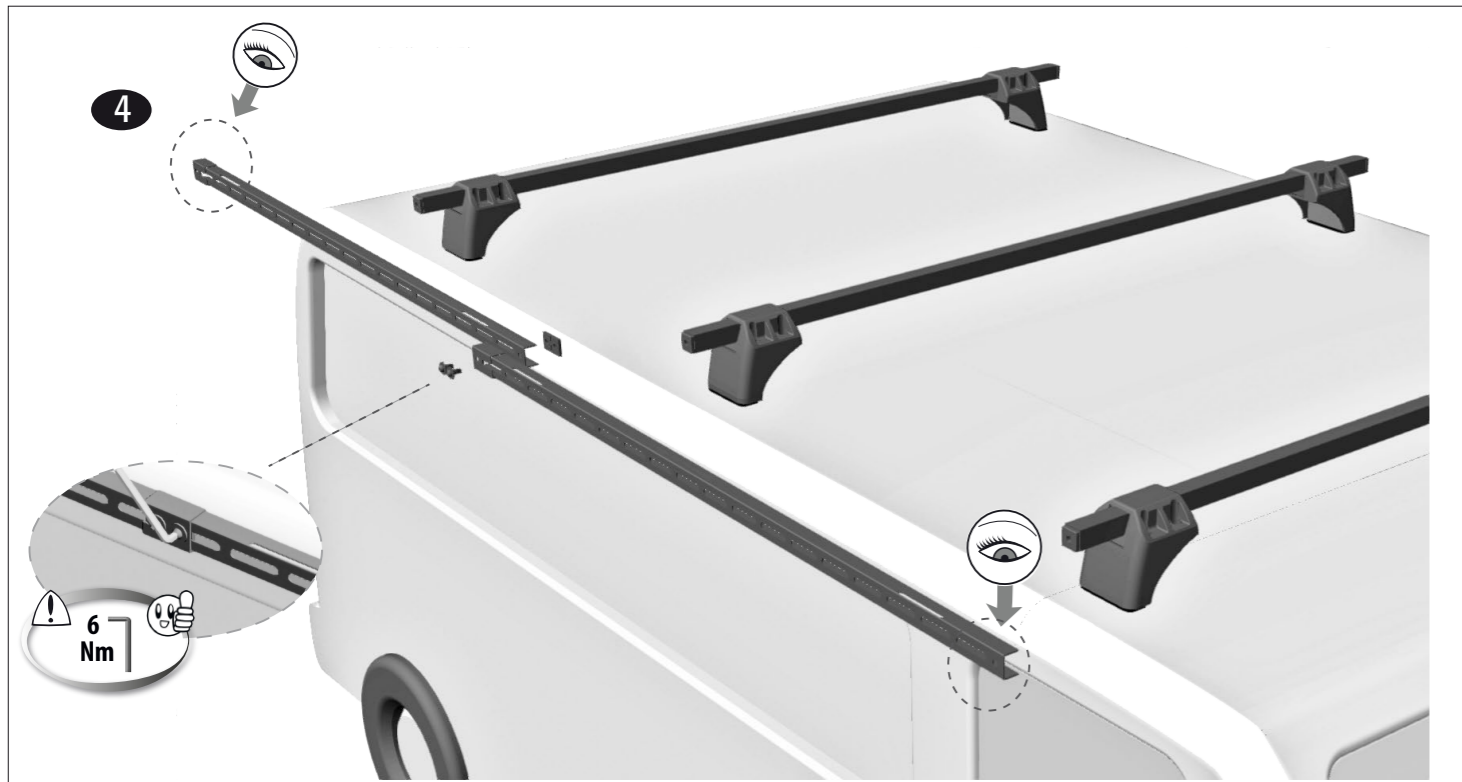

8

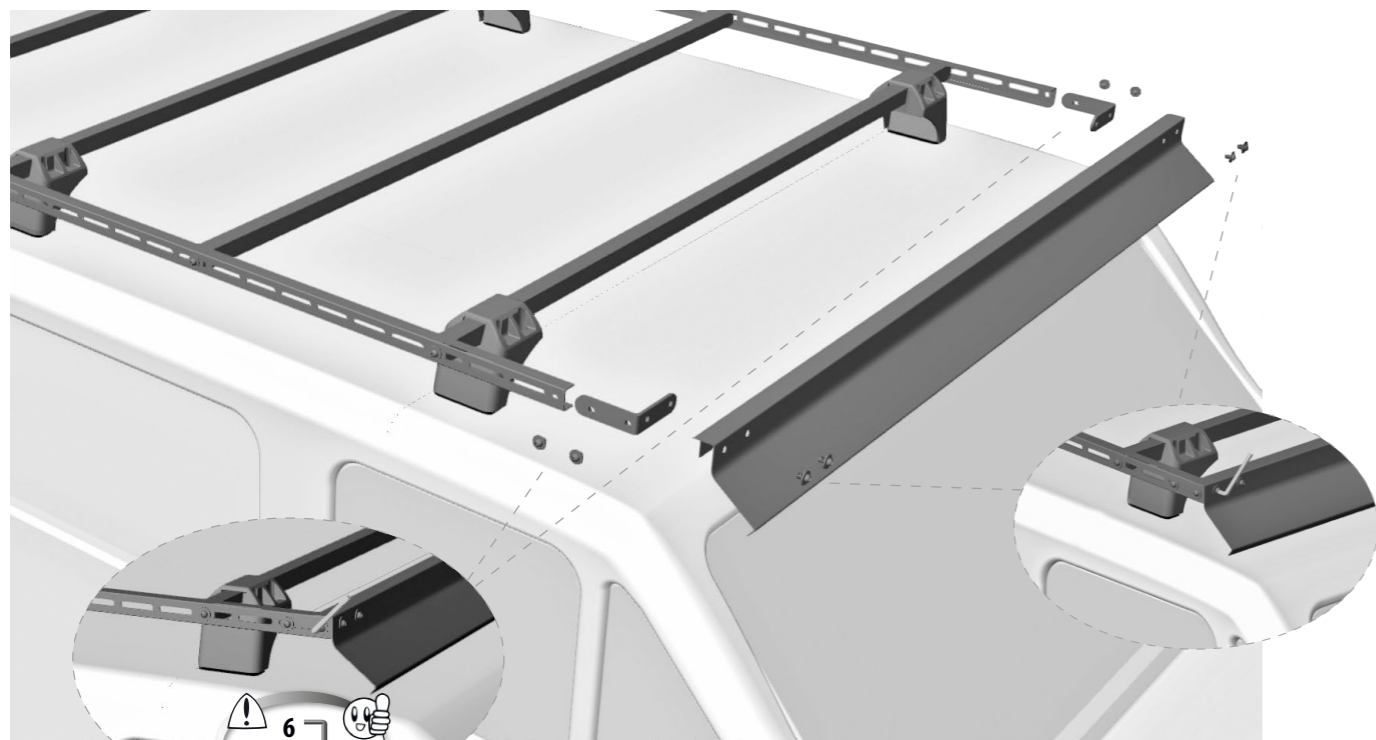

9

